

Installation Manual

Wave40 

 **Aqua-Hot**®

An AIRXCEL Brand

Wave40 DIESEL
AHE-WAV-DE1



CE DECLARATION OF CONFORMITY

Applicant:
Aqua-Hot Heating Systems, LLC
7501 Miller Drive, Frederick, CO 80504

Representative:
Can srl
Via G. Apolonio 11
36061 Bassano del Grappa Italy

We declare that the product(s) described below:

Product Name: Heater and Water Heater System
Product Model: WAVE40D - AHE-WAV-DE1

Complies with the provisions of the following European Directives:

1. Low Voltage Directive 2014/35/EU
2. Drinking Water Directive (EU) 2020/2184 ~ 98/83/EEC
3. Heating Systems in Vehicles UN ECE Regulation No. 122
4. Radio interference suppression in motor vehicles UN ECE R10
5. End-of-Life Vehicle Directive 200/53/EC

The product(s) have been assessed by the application of the following standards:

2014/30/EU Electromagnetic interference

- EN IEC 55014-1:2021 EMC Emissions
- EN IEC 55014-2:2021 Electromagnetic compatibility. Requirements for household appliances
- EN IEC 61000-3-2:2019/A1:2021/A2:2004 Harmonic emission limits for equipment with an input current up to 16 A per phase
- EN 61000-3-3:2013/A1:2019/A2:2021/AC:2022 Limitation of voltage changes, voltage fluctuations and flicker in public low-voltage supply systems, for equipment with rated current ≤ 16 A per phase and not subject to conditional connection

2014/35/EU Low Voltage Directive

- EN IEC 60335-1:2023/A11:2023 Household and similar electrical appliances. Safety General requirements.

IEC 60335-1:2020 CMV Safety of electrical appliances for household and similar purposes

UN ECE Regulation No. 122 Heating Systems in Vehicles

UN ECE R10 Radio interference suppression in motor vehicles

DIN 2001-2, KTW

- EN16421:2015 Drinking water supply from small units and non-stationary
~ EU 2020/2184~98/83/EEC and DIN2001-2





Gary Miller
Director of Engineering
Date: 24 June 2025

Airxcel Brand Portfolio

Contents

Introduction	1
Installing the Heater	6
Exhaust & Combustion Air Intake System	7
Hydronic Loop Install	12
Coolant Pump Installation	14
Fuel System	15
Inputting Serial Number	19
Fuel System Priming	19
Domestic Water System.....	20
Electrical Connections	22
Connecting to 12V DC Power	23
Connecting the Aqua-Hot to AC Power	23
Aqua-Hot LCD	24
Inputting Serial Number	25
INTERIOR HEAT & HYDRONIC	26
INTERIOR HEAT	27
HYDRONIC	28
Filling the Aqua-Hot.....	31
Initializing the Aqua-Hot.....	31
Communication Network Connectivity (optional).....	32
System Schematic	33
Winterization.....	35
Maintenance & Storage.....	35
System Checks	35
Troubleshooting.....	36
Warranty	38

Caution Notes

As you read this information, take particular note of the NOTICE, CAUTION, WARNING, and DANGER symbols when they appear. This information is important for safe and efficient use of the Aqua-Hot system.

NOTICE signals a situation where potential damage to the Aqua-Hot could occur.

NOTICE

CAUTION signals a situation where potential harm or risk of minor or moderate injury could occur if you do not follow instructions.

CAUTION

WARNING signals a hazardous situation where potential harm, risk of serious injury, or death could result if instructions are not followed.

WARNING

DANGER signals a situation where immediate risk of serious injury or death will result if instructions are not followed.

DANGER

NOTE: This manual will also use notes sections similar to this one to draw attention to features and practices which must be observed.

DANGER



Water temperature over 125°F can cause severe burns instantly, or death from scalds. Children, disabled, and elderly are at highest risk of being scalded. Feel water before bathing or showering! Temperature limiting valves are available.

Read and understand all instructions **before** installing the Aqua-Hot system. Aqua-Hot Heating Systems is not liable for damage resulting from failing to follow instructions contained in this, and any other Aqua-Hot documentation relevant to this unit.

- Read this manual **before** installing or using the Aqua-Hot System to reduce the risk of injury to persons or damage to the equipment.
- The product identity label contains specifications of the unit, to what standards it has been tested, and important safety notices.
- Disconnect electric wiring to the Aqua-Hot System before welding or plasma cutting the RV to avoid damage to the electrical components.



- Use caution when working on or near any diesel fuel system.
- DO NOT connect the 12-volt DC power to the Aqua-Hot if the vehicle requires welding.
- Use special caution when children are present. Children must not be allowed to play with the heater or perform cleaning and maintenance.
- All vehicle installations must comply with the requirements listed in National Standards ANSI/NFPA 1192, Diesel Standard for Vehicles, Specification for the installation of diesel systems for habitation purposes in leisure accommodation vehicles and accommodation purposes in other vehicles.
- At maximum operating temperature, the hot air outlet will be very hot that may result in serious burns or injury. Be aware of hot surfaces.
- The burner produces very hot temperatures that can ignite surrounding flammable materials. The burner should be turned off when loading or unloading flammable materials, and at fueling stations.



System Overview

The Aqua-Hot Wave40 Heater is a Heating System that can provide interior heat and hot water using a built-in electric heating element and a diesel burner. The heater can be used while driving.

There are two options for heating:

- **Diesel Mode:** the heater automatically adjusts power according to temperatures.
- **Electric Mode:** manually select either the 900W or 1800W heating mode according to the power supply capacity of the shore power.

Important Notes:

- Installation, repairs, and warranty work may only be carried out by a qualified technician. The heating system must be installed in accordance with local codes, or, in the absence of local codes, follow ANSI/NFPA 1192.
- Aqua-Hot will not be liable for problems or damage caused by the system being installed by unqualified technicians.
- This heating system has been certified for installation only in recreational vehicles as a Class I Appliance, not certified for use in boats.
- The Aqua-Hot heating system operates independently of the vehicle engine and is connected directly to the electrical system of the vehicle or towable.



WARNING!

Read and understand all instructions **before** installing the Aqua-Hot unit. Aqua-Hot Heating Systems is not liable for damage resulting from failing to follow instructions contained in this, and any other Aqua-Hot documentation relevant to this unit.

Improper installation, adjustments, service and maintenance can cause personal injury or loss of life. Reference the installation and user manuals **before** installation or service.

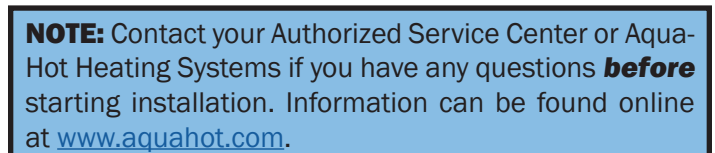

Safe Installation of the System

Become familiar with the installation process before installing in the vehicle or towable.

- Make sure to protect the unit during installation. Do not drop or stand on the heater.
- Routing of the fuel system and electric (110VAC & 12VDC) must be isolated and not in contact with fuel supply at any point of the installation.
- Only turn off the burner at the switch in the interior of the vehicle. It must be obvious to the user when the heater is switched on or off.
- Do not disconnect the 12V DC power supply prior to the purge cycle.
- Only shut down the burner via the battery disconnect in the case of an emergency or danger.
- Do not allow the wiring or wiring harness to come into contact with sharp edges on metal panels. The wires can become damaged and short circuit and potentially cause a fire. Use caution when installing the wiring.
- Protect any vehicle parts near the burner from excessive heat damage, or from contamination from fuel.
- The serial label must be visible and legible after the heater has been installed.
- All precautions must be taken to minimize the risk of personal injury or damage to the burner or vehicle.

Fuel Supply

- Do not use the heater in enclosed spaces such as a garage. The fumes produced from the exhaust can be toxic. Do not use the burner while refueling or while other appliances are being serviced or refueled.
- The fuel shall meet national standards ANSI/NFPA 1192 Diesel Standard for Vehicles. The fuel system must comply with the technical and administrative regulations of the respective country of use.

Exhaust System

- Do not operate the heater in an enclosed space or a space that does not have exhaust ventilation. Fumes from the exhaust may be toxic.
- The exhaust system must be positioned so that the fumes will not get into the interior of the vehicle through ventilation openings or windows.
- *Exhaust termination location must comply with ANSI/NFPA 1192 Handbook for Recreational Vehicle Standards.*



WARNING

If the information in this manual is not followed exactly, a fire or explosion may result, causing property damage, personal injury or death.

Air Intake Inlet

- The burner combustion chamber air must not be taken from the interior of the vehicle, only fresh air from the exterior.
- An intake line is required for the intake air.
- The air inlet must be positioned in an unobstructed manner.

THE AQUA-HOT's EXHAUST IS HOT!

- Do NOT operate the burner inside an enclosed building.
- The heater must be switched OFF when refueling.
- The heater is not to be operated while the vehicle is being refueled, if the towing vehicle is being refueled, if the vehicle is in motion, or if the vehicle is in an enclosed space.
- The heater is not to be used while any appliances are being refueled or serviced.
- Aqua-Hot will not be liable for problems and/or damage caused by the system installed by untrained technicians.



WARNING

The heating system can produce dangerous CO gas when the fuel system is operating if not properly installed or operated. Read all safety instructions before install or use.



For full details and installation requirements, please see installation and owner's manuals.

Minimum Service Clearances

Front - 11,00cm
 Back - 3,00 cm
 Sides - 2,00 cm
 Top - 5,00 cm

Bottom - No Clearance Necessary

This appliance must be installed in accordance with local codes or, in the absence of local codes, the Standard for Recreational Vehicles



10R - 06 1489
122R - 00 0088

Max Water Pressure	6,9 Bar
Power (DC)	12VDC, 14A
Power (AC)	220VAC, 8.2A, 1800W Max
FUEL TYPE	DIESEL
Burner Input Rating	2 - 10 kW

Model Number: AHE-WAV-DE1
 Serial Number: AHE-XXXXXX

NOTE: This product label is attached to the side of the Aqua-Hot, and provides a ready reference to specifications, test standards, and important safety notices.



As with any appliance, allow the Aqua-Hot to completely shut down BEFORE disengaging the RV 12V power disconnect.

All vehicle installations must comply with the requirements listed in the Recreational Vehicle Industry Association's (RVIA) ANSI/NFPA 1192 Handbook for Recreational Vehicle Standards.



Figure 1

Wave40 Technical Specifications

Fuel Type		DIESEL	
Operation Modes		Domestic Water Heating / Interior Heating / Hydronic Heating	
Operating Voltage Range	VDC	10.5 – 15	
Burner Heating Power Control Range	BTU/hr (kWh)	6,800 (2) / 13,600 (4) / 20,400 (6) / 27,300 (8) / 34,200 (10)	
Air Heating Control Range	BTU/hr (kWh)	6,800 (2) / 13,600 (4) / 20,400 (6)	
System Power Consumption at 12VDC Min-Max	Amps	3.5 Low Heat	8.5 High Heat
AC Electric @ 110VAC	Watt	900 / 1800	
AC Electric @ 110VAC	Amps	7.8 / 15.6	
Fuel Consumption Min-Max	gal (L)	0.049 (0.18) / 0.246 (0.93)	
Water Heating 45° F Temperature Rise	gal (L)	1 (3.8)	
Fuel Pressure Max	psi (Bar)	40 (2.75)	
Domestic Water Pressure Max	psi (Bar)	100 (6.9)	
Coolant Capacity	gal (L)	3.25 (12.3)	
Warm Air (4 set points Manual or Auto)	CFM (m³)	75 (2.12) / 180 (5.1)	
Altitude Operation Auto	ft (m)	15,000 (4572)	
Hydronic Loop Capacity (optional)	BTU/hr (kWh)	27,300 (8)	
Dimensions	in (mm)	20 (508) L x 17.5 (445) W x 12 (305) H	
Weight	lbs (kg)	42 (19.1)	

Aqua-Hot Wave40 Heater

1. Glycol Fill
2. Diesel Fuel Connection
- 2a. Propane Fuel Connection
3. Auxiliary Hydronic Loop
4. Mounting Bracket
5. Hot Water Outlet
6. Domestic Water Inlet
7. Return Air Inlet
8. Combustion Air Inlet/Outlet
9. Control Unit
10. Electrical Inlet
11. Warm Air Outlets
12. Glycol Tank Overflow
13. LCD Screen

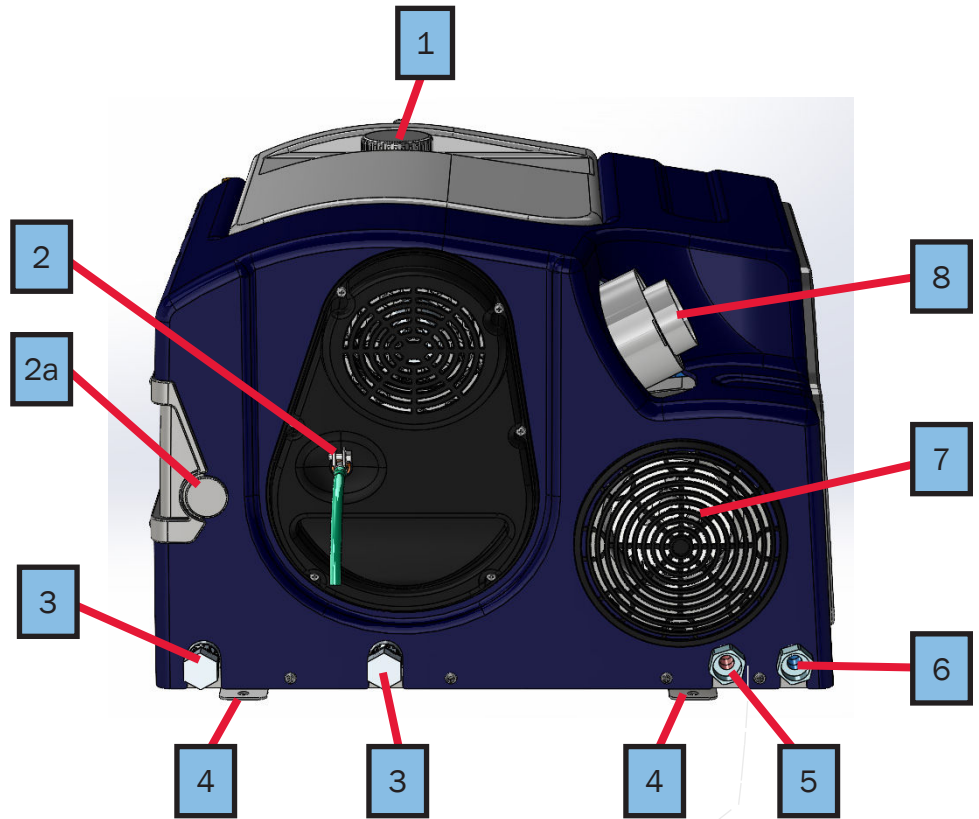

Figure 2

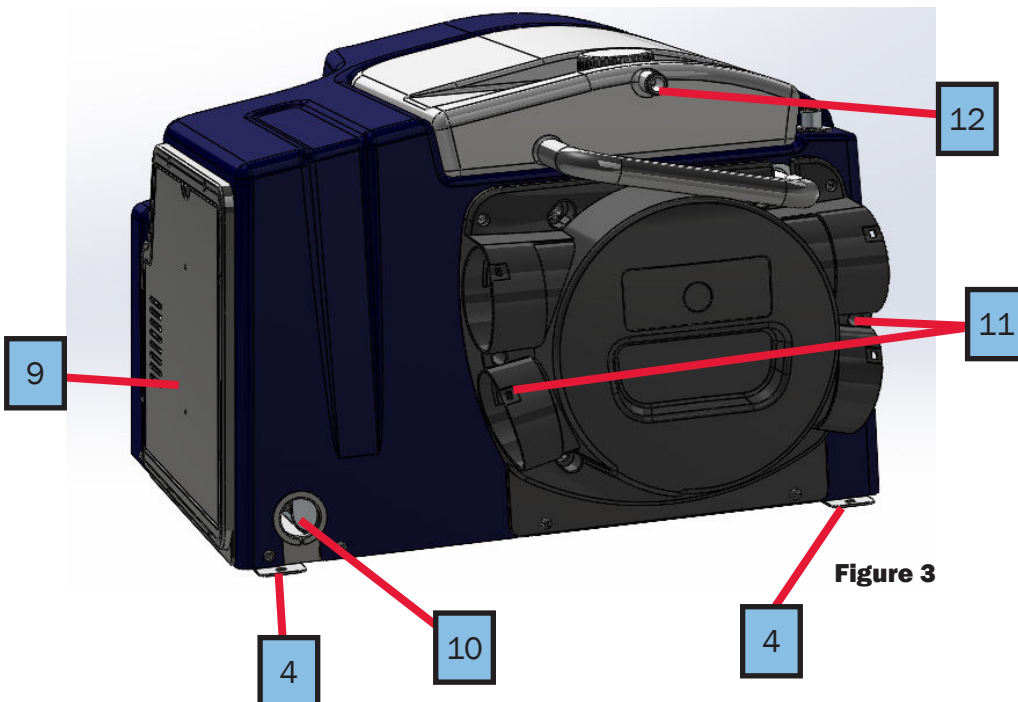

Figure 3



Figure 4

Installing the Heater

Install the Aqua-Hot in a compartment which protects the unit and allows service access to the top and front panel of the Aqua-Hot. This heater must be installed in the RV's interior.

1. Reference the following illustrations below for mounting information.
2. Secure the Aqua-Hot to the RV floor using appropriate mounting hardware to suit flooring material and tolerances.
3. The Aqua-Hot is best placed where easy access to the top, front, and side electrical panel is guaranteed for service.

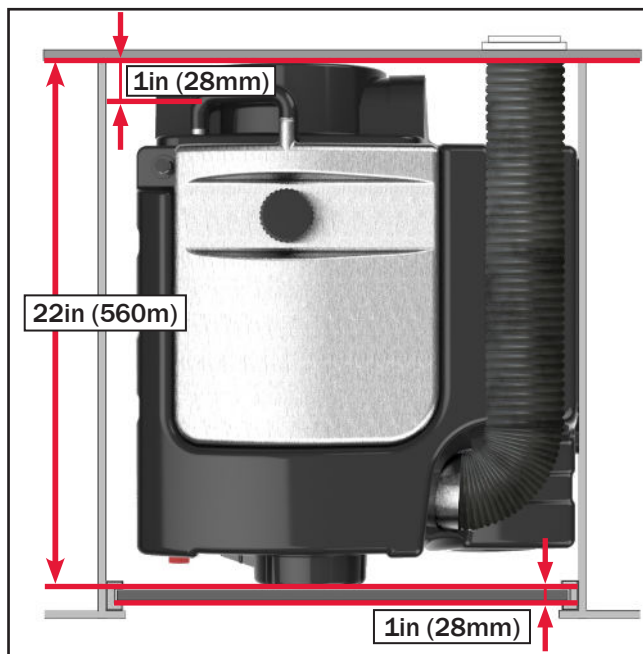

Figure 5

Support and Clearances

Make the following considerations when supporting the Aqua-Hot to ensure its most optimal operation and location. **NO COVER IS ALLOWED ON THE HEATER**

- Ensure that the floor of the mounting location can support at least 70lbs (32kg).
- Use (3) mounting screws to the aluminum/plastic frame feet to secure the Aqua-Hot in place on the RV floor to prevent damage to the fuel lines during driving and operation.
- The best place for the Aqua-Hot heating system is in the center cabinet or storage space to ensure that the heater evenly distributes heat, making sure there is ample space to remove the service panels on the top and side.
- Exhaust pipe minimum length is 24in (610mm) and the maximum length is 39in (991mm).

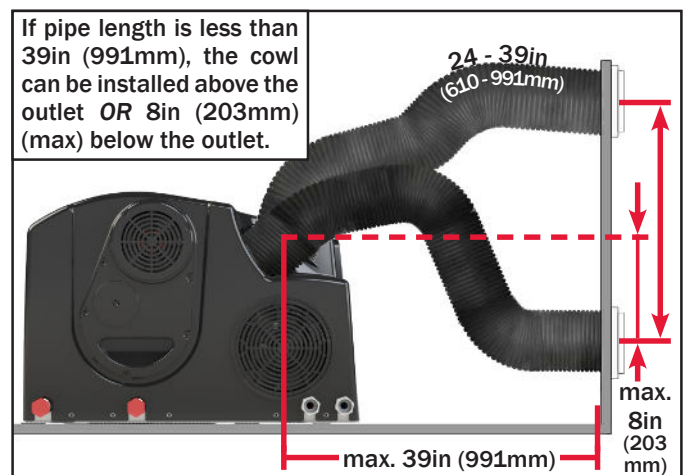

Figure 7



Figure 6

Exhaust & Combustion Air Intake System

The exhaust pipe passes through the air intake pipe. The exhaust pipe should be slightly shorter than the intake pipe. The exhaust vent must be installed on the side wall.

The length of the intake and exhaust pipe is 3.3ft (1 meter). Reference figures 5-7 for permissible routing.

- The air intake shall not be supplied from living areas. The air intake opening must not point in the direction of travel. It should be free from potential clogs from snow, debris, or water.
- There is no air pressure difference between the exhaust gas outlet or air inlet.
- The air intake pipe must be positioned in a way that the intake will not terminate within the vehicle interior.
- Exhaust termination location must comply with ANSI/NFPA 1192 Handbook for Recreational Vehicle Standards.

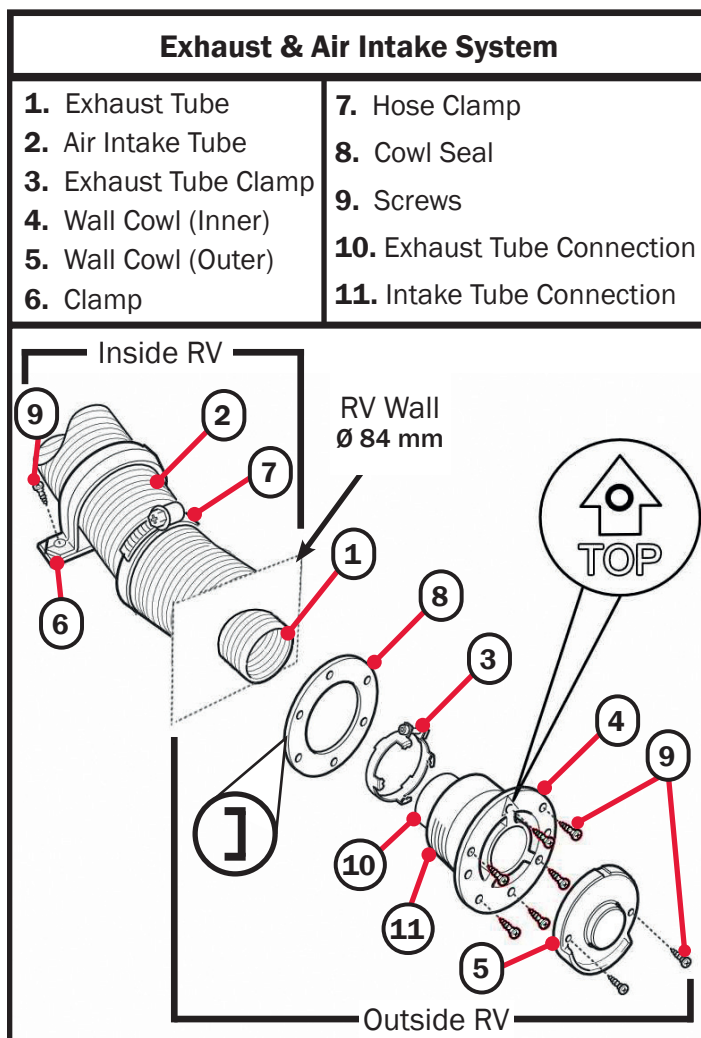

Figure 8

Exhaust Cowl (Air inlet & outlet) Installation

- Cut the exhaust pipe and air intake pipe to length.
- If either end is damaged or bent, cut off approximately 0.8in (21mm).
- Slide the air intake pipe over the exhaust pipe.
- Select a flat mounting surface so that intake air can enter from all sides.
- Drill one hole (Ø 84 mm) in the RV wall and seal with the gasket (Figure 9 #8) smooth side facing the exhaust vent and gasket facing the RV wall (Figure 9 #3).
- Slide a hose clamp (#3) over the exhaust and insert the pipe into the drilled hole. Tighten the clamp (torque 2.5 - 3 ft-lb / 3.4 - 4.1 Nm).
- Insert the air intake pipe onto the ridges of the exhaust cowl (#11).
- Use 6 screws (#9) to secure the exhaust cowl. Make sure "TOP" faces upward.
- Use 2 screws to secure the exhaust cowl cover and then secure the exhaust pipe to the RV wall with the mounting clamp (#6).

CAUTION

**Sharp edges are present during the exhaust installation.
Wear protective equipment during assembly.**

All vehicle installations must comply with the requirements listed in the Recreational Vehicle Industry Association's (RVIA) ANSI/NFPA 1192 Handbook for Recreational Vehicle Standards.

- Should this particular application require modification, please contact Aqua-Hot Heating Systems at (800) 685-4298 for further assistance.

DANGER

RISK OF CARBON MONOXIDE POISONING
If RV or heater exhaust enters the RV, carbon monoxide in the exhaust can poison people causing serious injury or death.

Connecting Exhaust & Combustion Air Inlet to Heater:

- Insert exhaust pipe with o-ring (#2) into the exhaust port as deep as possible.
- Attach c-clip (#1) into the two holes on the heater's exhaust port to secure the exhaust in place.
- Place the air intake pipe (#4) over the inlet port.
- Place the clamp (#3) and tighten.

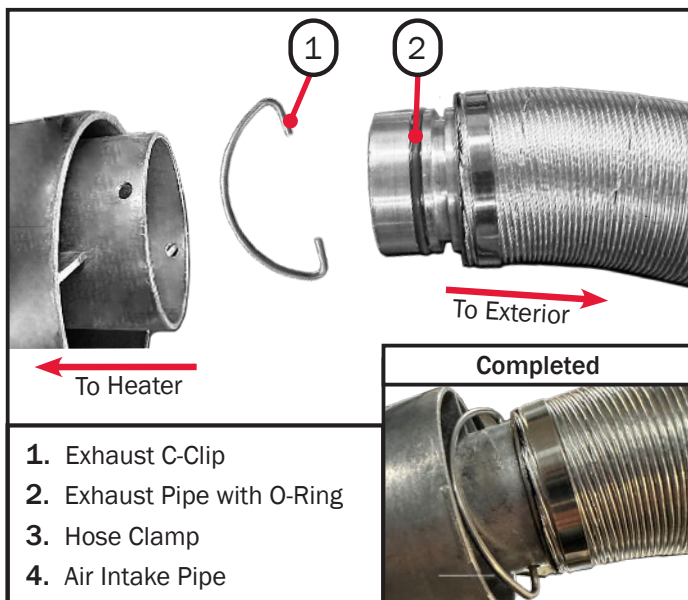

Figure 9a

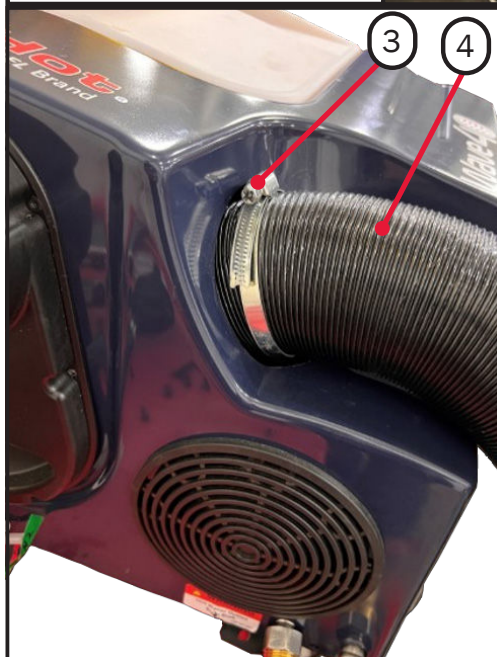

Figure 9b

Circulated Air Intake Installation

- The heater draws in circulated air from inside of the RV
- The air intake opening must be installed in a position so no exhaust fumes can be drawn in.
- The air inlet grate (#1) between the RV's living space and Wave40's compartment space must be at least 23 in² (149cm²).

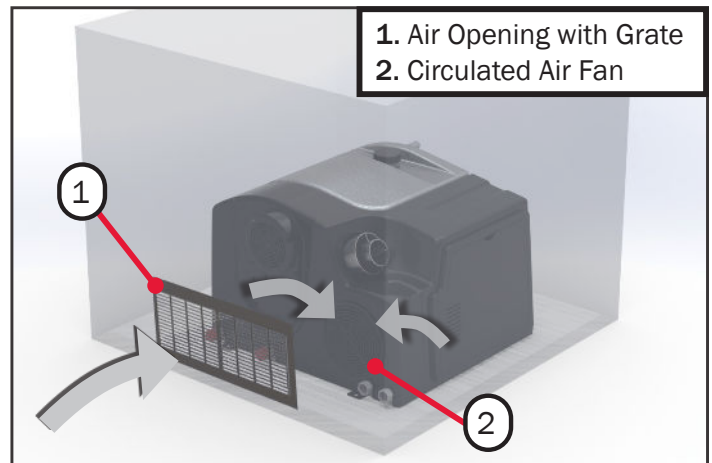

Figure 9c

NOTE: For increased performance and reliability, a return air filter at the grate is recommended.

The use of a filter will ensure the air blower wheel remains clean of dust and debris.

Warm Air Distribution Installation

- Warm air is distributed to the RV interior by flexible air ducts.
- The air ducts must be properly installed for the heater to correctly operate. The ducting from each outlet should be at least 3 feet (1m) long. Equal length ducts are ideal for even air distribution throughout the cabin.
- The longer ducts should be connected to the upper outlets.
- At least **3 of the 4** warm air outlets must be used for proper distribution of heat.
- The air outlets are connected to air ducts with an outside diameter of 2.6in (66mm).
- Each air duct must have at least one end outlet. The air outlet duct must be firmly inserted into the connection port.
- It is recommended to use 90° elbows for bends, keep the bends to a minimum
- If the duct length is less than 80in (2m), the air duct should not be installed higher than the air duct connection on the Wave40 to prevent unwanted interior heating when the system is only in hot water mode.
- If the duct length is less than 20in (50cm), form a U-shaped trap near the air outlet (Figure 11) to prevent unwanted interior heating when the system is only in hot water mode.

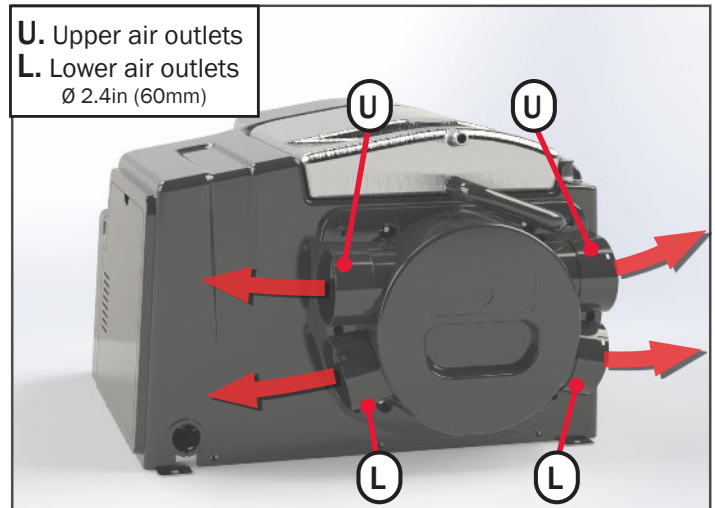

Figure 10

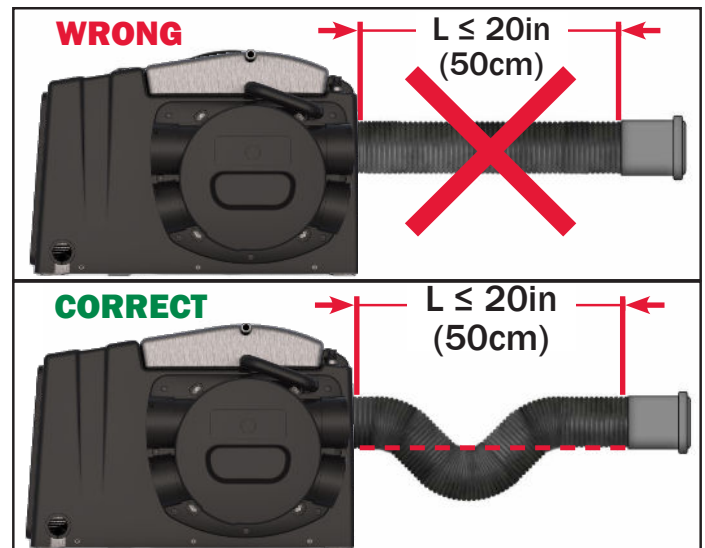

Figure 11

Installation for Wall Clamp Style Air Outlets

Parts: EXX-WAV-650

1. Drill a hole with a diameter of $2\frac{3}{8}$ (60mm) inches into the wall.

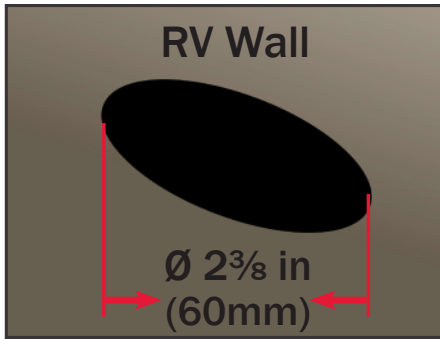

Figure 12

2. Attach the warm air duct to the backing nut or backing tee and place on the inside of the wall.



Figure 13

3. Insert the air outlet through the wall and screw into the backing nut or backing tee until firmly seating against the wall.

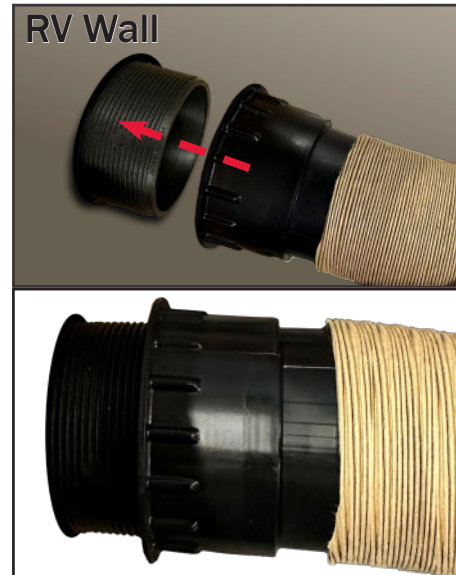
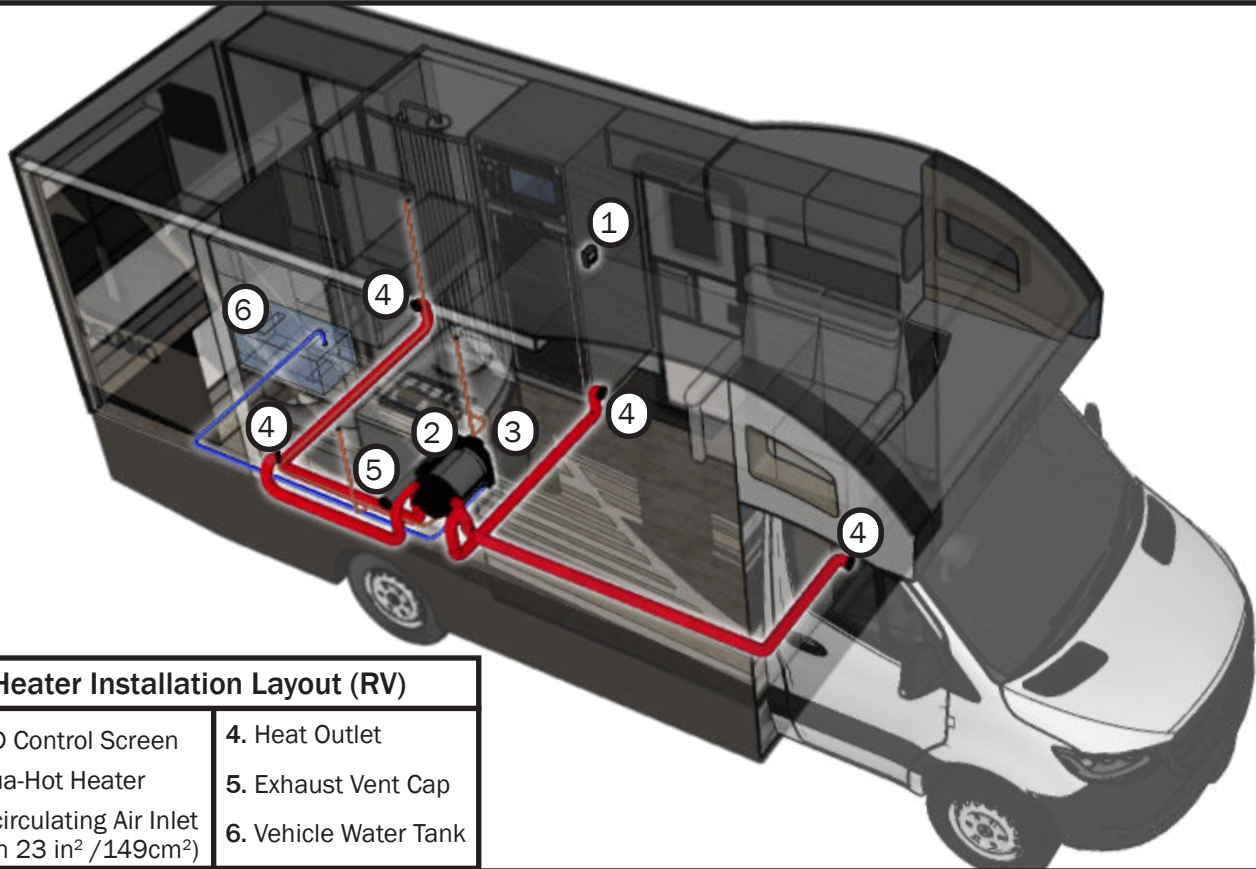

Figure 14

NOTE: The illustrations below are samples for the layout of the Aqua-Hot heating system. Actual placement may vary on the individual design of the RV. For questions or assistance, contact us at (800) 685-4298.



Heater Installation Layout (RV)

- | | |
|---|-----------------------|
| 1. LCD Control Screen | 4. Heat Outlet |
| 2. Aqua-Hot Heater | 5. Exhaust Vent Cap |
| 3. Recirculating Air Inlet
(min 23 in ² /149cm ²) | 6. Vehicle Water Tank |

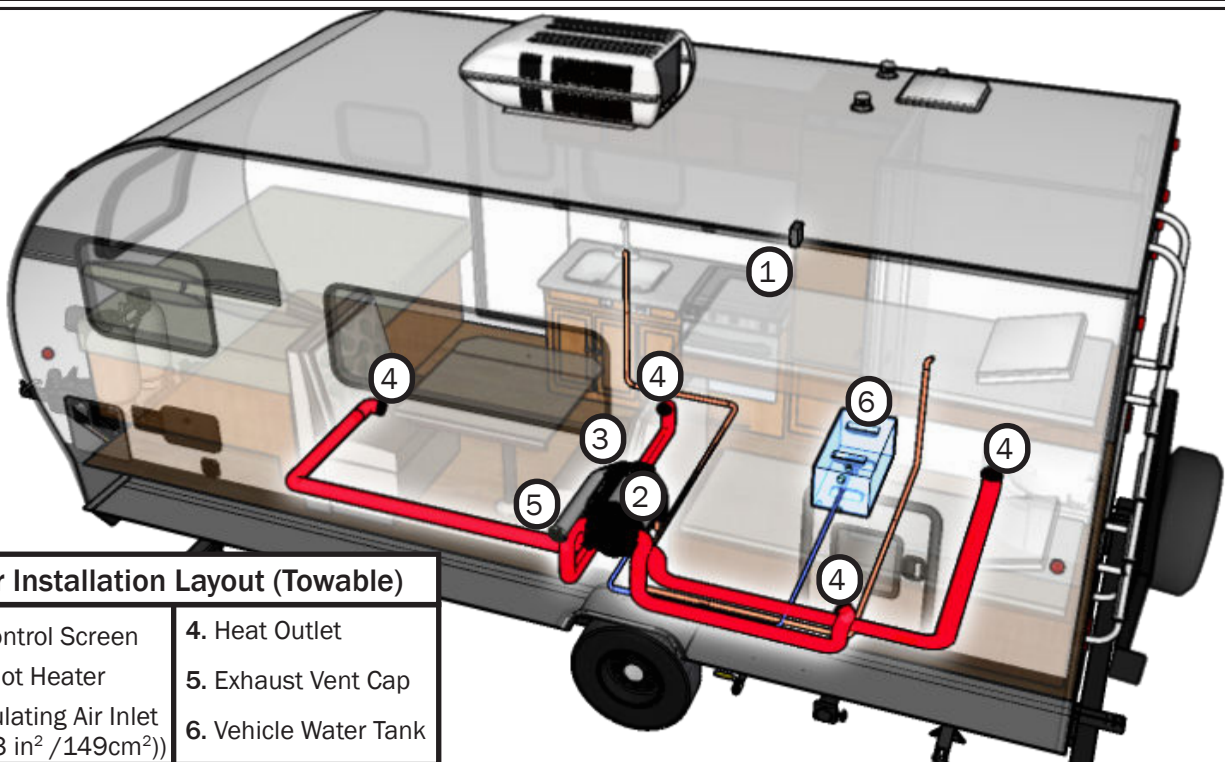

Heater Installation Layout (Towable)

- | | |
|---|-----------------------|
| 1. LCD Control Screen | 4. Heat Outlet |
| 2. Aqua-Hot Heater | 5. Exhaust Vent Cap |
| 3. Recirculating Air Inlet
(min 23 in ² /149cm ²) | 6. Vehicle Water Tank |

Figure 15

Hydronic Loop Install

The hydronic loop installation provides remote heating, allowing the heat exchangers to heat exterior RV compartments such as water bays or water storage tanks. This hydronic loop may also be used for in-floor radiant heating.

The following guidelines should be used when planning the coolant loop for the heating zone. The Wave40 requires a single fluid zone. Failure to adhere to these installation principles can hinder the operation of the heat exchangers.

- All plumbing should be installed as flatly as possible.
- One to three (maximum) Aqua-Hot heat exchangers may be used.
- Drain valve must be easily accessible.
- Do not use brass fittings on the zone supply or zone return. Use 3/4" plastic barb. See Parts & Accessories on page 36.
- Extreme rises in height should be avoided to avoid any potential air traps.
- Use 5/8" (15.9mm) ID plumbing lines, 3/4" (19.1mm) SAE J20 type coolant hose, heater hose, or 1/2" (12.9mm) ID PEX tubing for the single heating loop.
- Use wide-sweeping elbows or "bend supports" whenever the plumbing lines may be susceptible to kinking.
- Plumbing lines should be run in areas where there is no reasonable possibility that they can be pinched off or damaged under normal operating conditions.
- Secure all lines where necessary and apply protective shielding in areas where chafing may occur.
- Rubber coated/closed-type clamps are recommended when securing the plumbing lines.
- Inlet and outlet plumbing lines can be installed with a straight fitting or an elbow.

Instructions

1. Layout the plumbing lines for all heat exchangers .
2. Label each line and designate as an outlet or an inlet line.
3. Connect and clamp the outlet line from the heater to the lowest port (inlet port).
4. Connect and clamp a line from the first heat exchanger's highest port, and connect the other end to the next heat exchanger's lowest point.
5. Connect each additional heat exchanger in the same arrangement.
6. Connect and clamp the inlet line from the heater to the highest port on the last heat exchanger to complete the heating loop.

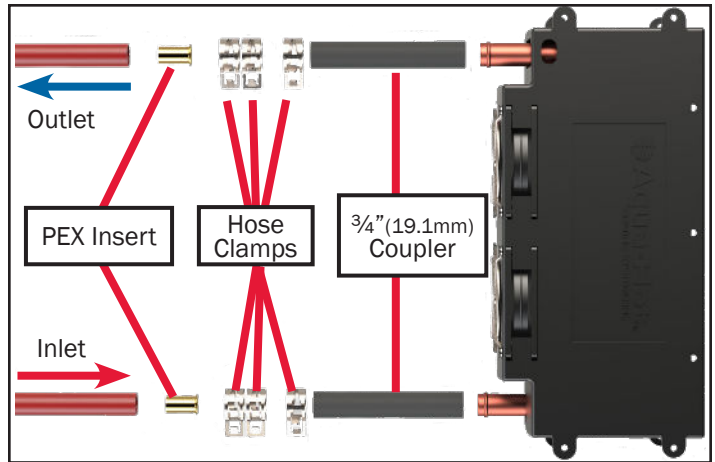

Figure 16

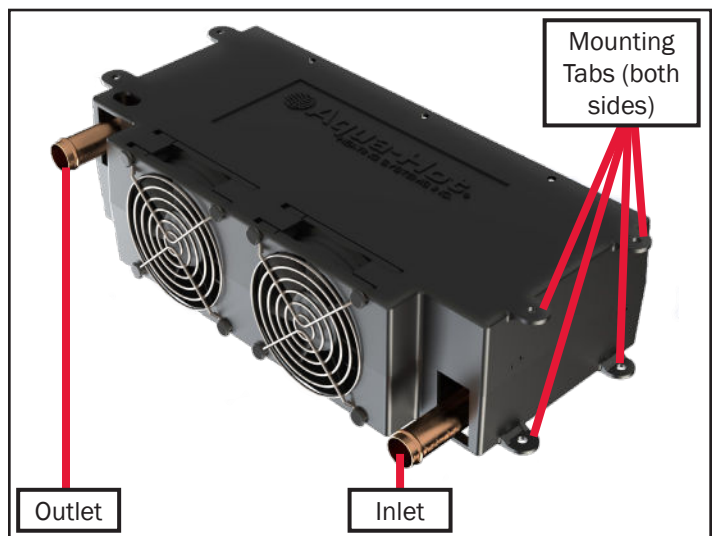

Figure 17

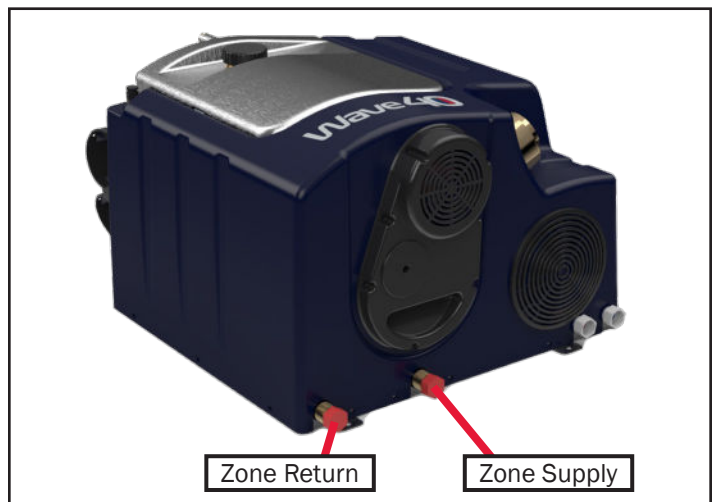

Figure 18

INS-WAV-AUX		
Part Number	Quantity	Part Description
PLX-T44-006	4	Fitting, Insert Modified Brass
PLX-A65-200	4	Fitting, Brass Barb, 3/4"x1/2"(M) NPT
PLX-CTB-270	12	Clamp, Hose, Constant Tension, 0.75"
PLX-125-200	2	Fitting, 3/4" Barb x 1/2" FNPT, Brass
PLX-250-208	1	Nylon, Tee 1/2" NPT, 3/4" Barb
PLX-BV1-200	3	Valve, Ball 1/2" (F) NPT

INS-WAV-AUX		
Part Number	Quantity	Part Description
ELE-400-900	1	Pump Harness
ELE-WAV-540	1	NTC, Room Temperature Sensor
PLX-250-204	1	Plug, 1/2" NPT
HDX-317-7T2	1	Pump Mount
PLX-100-900	1	Coolant Pump

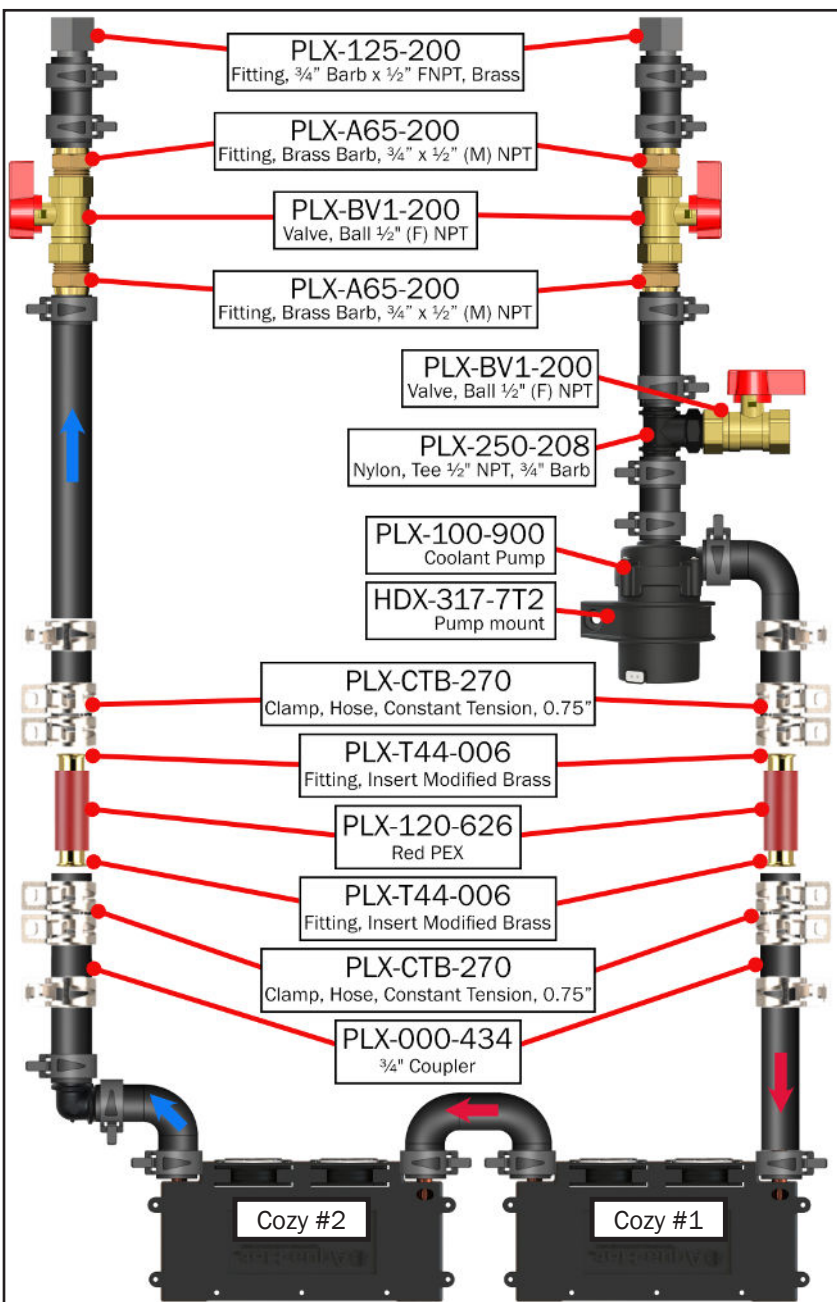
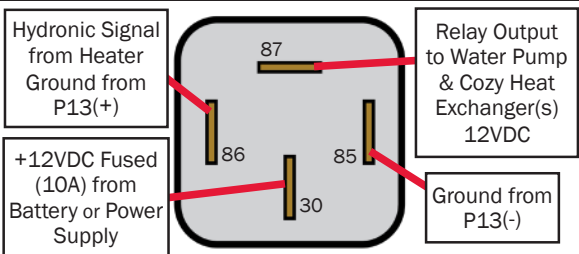

Figure 19

Hydronic Auxiliary Relay (provided by installer)



NOTE: The heater provides a signal to operate a relay to turn on/off water pump and heat exchangers.

NOTE: The pump ground and cozy fan ground connect to battery or power supply.

The pump must be installed ≤ 5 feet from the heater for easier fill and priming of the Aqua-Hot.

NOTE: This diagram is simply a reference to show the layout and flow of the plumbing to and from heat exchangers. Placement and quantity may vary depending on the RV.

Coolant Pump Installation

To prevent air entrapment (which can lead to no flow) or cavitation issues at the coolant pump, the following mounting guidelines must be followed.

Coolant Pump Performance

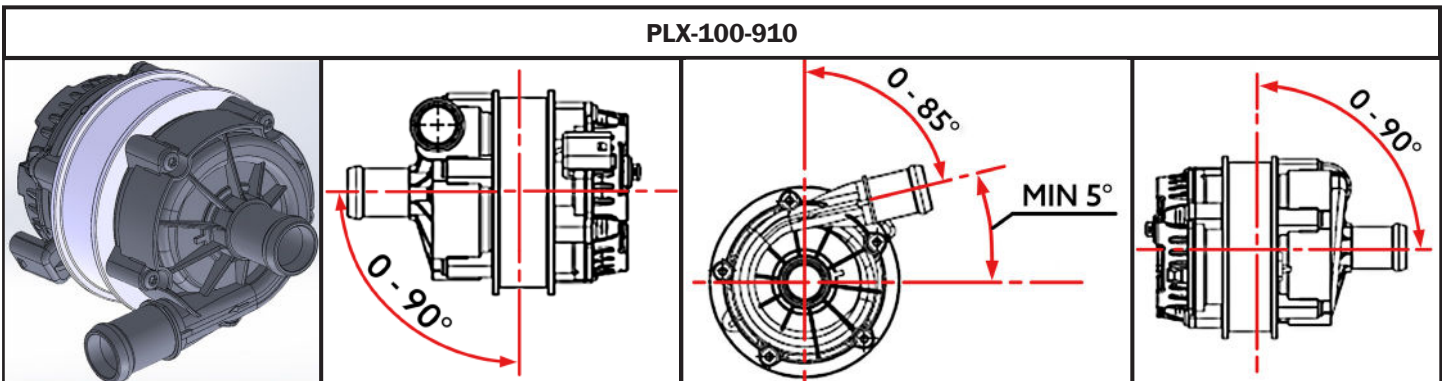
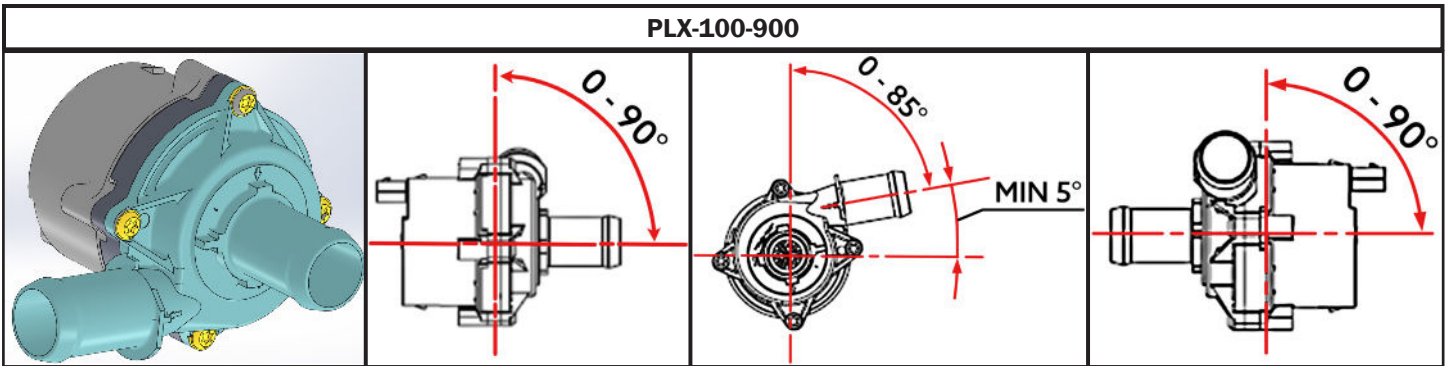
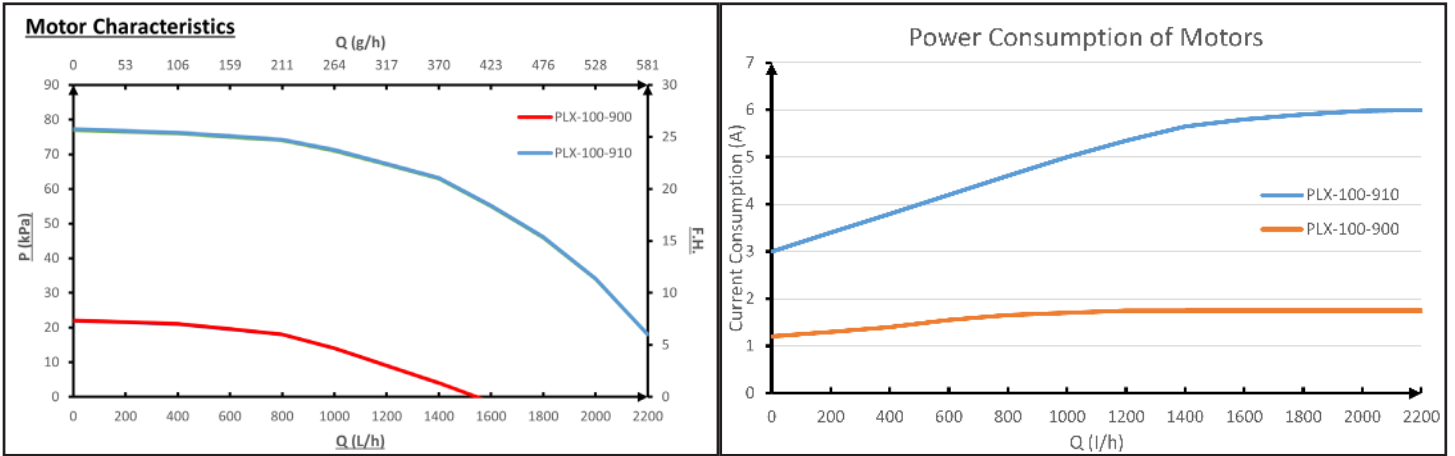

Figure 20

Fuel System

Fuel System Requirements

- Select the fuel standpipe or fitting applicable to the vehicle tank. There are 3 options available and are purchased separately for the application.
- The diesel fuel supply should be drawn directly from the vehicle's main fuel tank if applicable. A separate fuel tank may be installed if necessary.
- The fuel tank should be equipped with a dedicated fuel pick-up pipe. Make sure the fuel standpipe does not impair the operation of the vehicle's fuel delivery or fuel gauge in any operating mode.
- The fuel standpipe must be positioned vertically and the end should sit at least 1in (25mm) above the tank bottom.
- The hole on the fuel tank should be smooth and flat to confirm good sealing.



Fuel Pickup

- The SAE 7.89 fuel line adapter can attach directly to the external burner fuel tap included on some fuel tanks
- The fuel standpipe can be used where no fuel tap is provided.
- Fuel must be drawn directly from the vehicle's fuel tank.
- This application requires a dedicated fuel pickup that cannot be shared with any other appliance.
- The end of the fuel pickup must sit 1.5 – 2" (38-51mm) above the bottom of the tank preventing the heater from consuming all the fuel, stranding the vehicle.

Select the fuel standpipe or fitting applicable to the vehicle tank. The 3 options below are available and are purchased separately for the application.

Installing the SAE 7.89 Adapter:

1. Apply a small amount of gas to the rubber seal inside the adapter.
2. Slide the adapter onto the fuel pickup until a click is felt.
3. Gently pull on the adapter to ensure it is locked in place.



Figure 21

Installing the Fuel Standpipe:

1. Drill a 6mm (1/4") hole through the top of the fuel tank. To make installation easier, place the hole close to the fuel sending unit for the vehicle. Prevent any chips and shavings from falling into the fuel tank.
2. Cut the standpipe to length. Remove any burrs and debris.
3. Slide the standpipe a short distance into the hole. Slide the nut onto the standpipe inside the tank and thread the nut onto the standpipe threads.
 - The standpipe nut must be installed from inside the tank. The vehicle's fuel sending unit must be removed to gain access to the inside of the fuel tank.
4. Tighten the nut making sure the standpipe port is aimed correctly.



Figure 22

Installing the Fuel Standpipe Metal Tank (Part No. FLX-001-050)

1. Drill a 1 inch (25mm) hole through the top of the fuel tank.
2. Deburr and remove any sharp edges from the hole to ensure a good seal.
3. Determine the length of the standpipe so the end is at least 1 inch (25mm) above the bottom of the fuel tank.
4. Cut off excess standpipe at a 45° angle, remove any sharp edges.
5. Loosely assemble parts.
6. Place the gasket between the inner wall of the tank and the intake nozzle with a washer and provided nut. Tighten the nut to a torque of 4.5ft-lb ($\pm 1\text{ft}\cdot\text{b}$)/(6.1Nm $\pm 1.9\text{Nm}$). Do NOT over-tighten the nut to prevent the rubber washing becoming distorted.

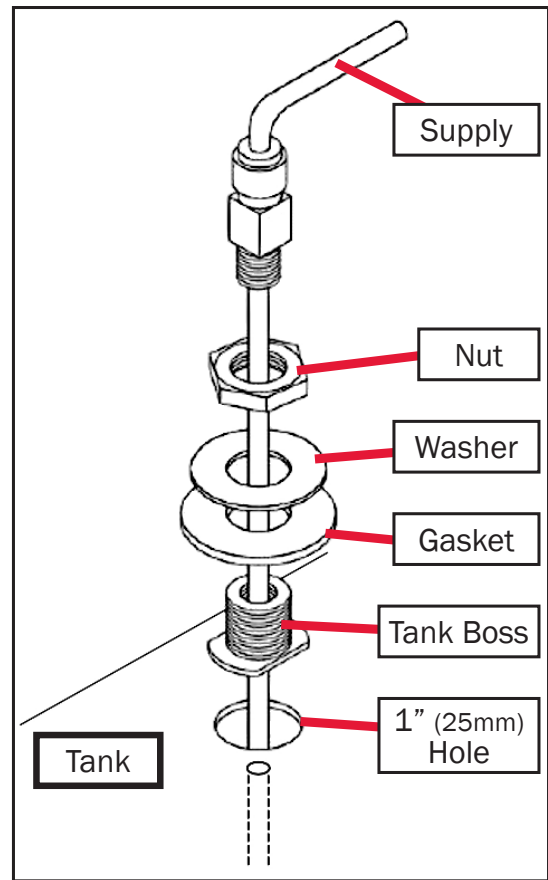

Figure 23

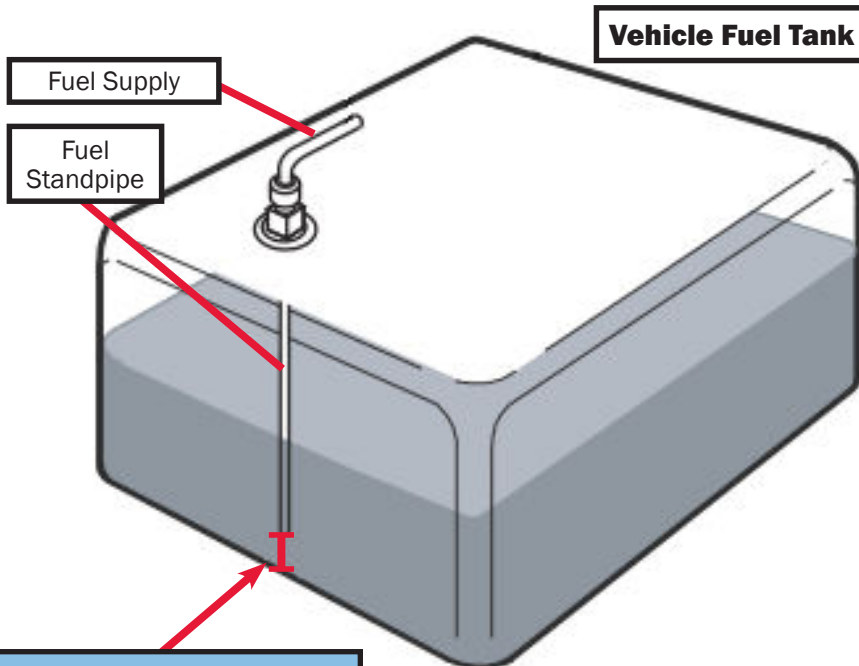

Figure 24

NOTE: The end of the fuel standpipe must be a minimum distance of 1 inch (25mm) from the bottom of the fuel tank.

NOTE: Additional fuel standpipe options are in the Parts & Accessories section on page 38.

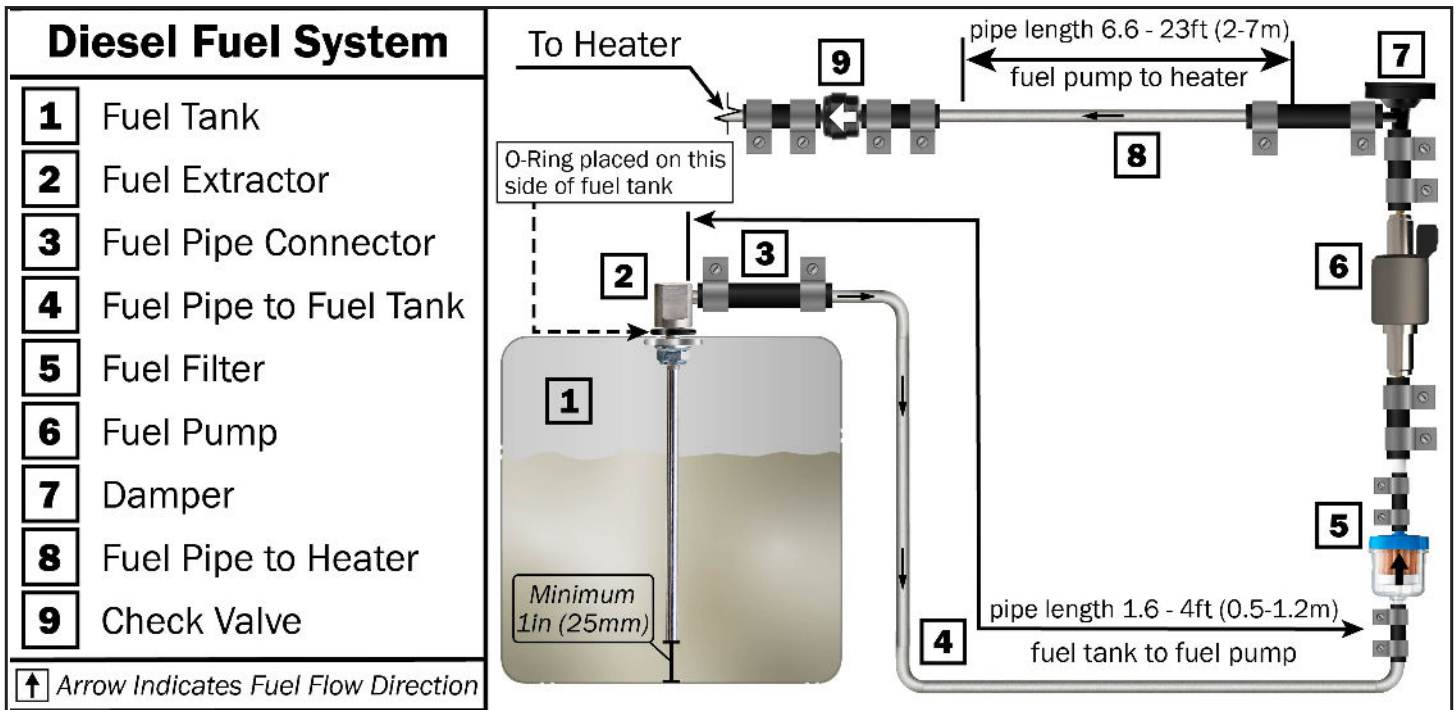

Figure 25

Fuel Lines Requirements

- Please refer to the example diagram shown above.
- Use the provided fuel line with the included couplers and clamps.
- The fuel line should not be descending from the fuel pump to the burner - see Figure 25.
- The fuel line should be properly secured to avoid sagging.
- The fuel line must be installed in a manner that won't cause damage to the fuel line (i.e. close to exhaust).
- The fuel line should be mounted and secured with hose clamps. The hose clamp must be tightened so that the two tabs on the clamp touch each other.
- The fuel line must be kept as short as possible. The total length of the fuel line should not exceed 39ft (12m). The maximum length of the inlet fuel line is 6.6ft (2m), and the maximum length of the pressure is 20ft (5.1m).
- The fuel line should be laid out as flatly as possible, avoiding extreme rises in height to eliminate any air traps.
- The fuel check valve (Figure 25 #9) must be installed between the heater and fuel pump (Figure 25 #6).
- The fuel system must meet national standards ANSI/NFPA 1192 Diesel Standard for Vehicles.

WARNING

Do NOT use bio-diesel with the fuel lines. Doing so will result in damage to the burner and fuel system. Please follow instructions to ensure safe operation. Always check for any fuel leaks before operating the burner.

Fuel Filter

- A fuel filter should be installed before the fuel pump to ensure that clean fuel is delivered to the burner at all times.
- Make sure the fuel filter is installed in an accessible area, so it can be replaced during service.
- It is recommended to replace the filter, tubing connection head and clip every year.
- The filter can be mounted vertically or horizontally; note the installation position and direction of flow (see Figure 29).

Fuel Pump

- Fuel Pump is required to be installed vertically. It is not recommended to mount the assembly rotated 180° (see Figure 27).
- It must be fixed with a rubber clamp and should be inclined upward. Do not install near the exhaust pipe.

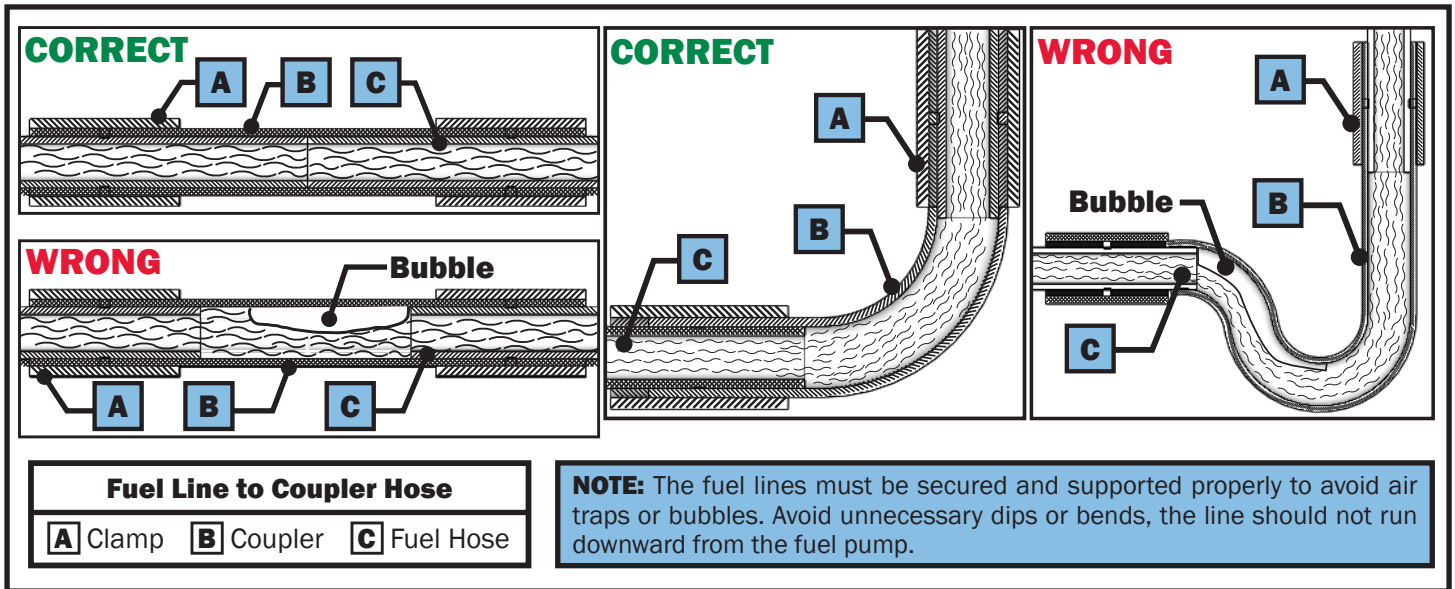

Figure 26

NOTE: Mount the fuel pump and filter in a location that is accessible for ease of service & maintenance.

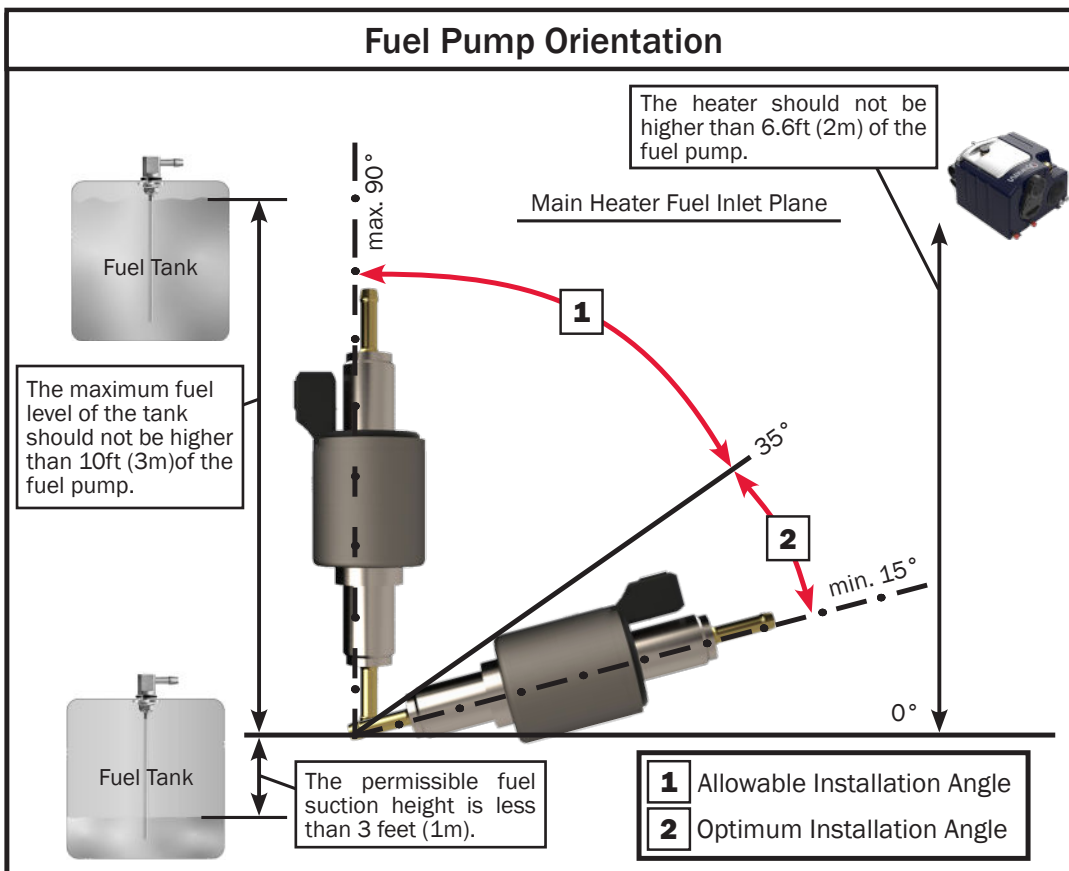

Figure 27

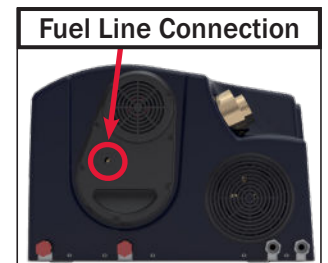

Figure 28

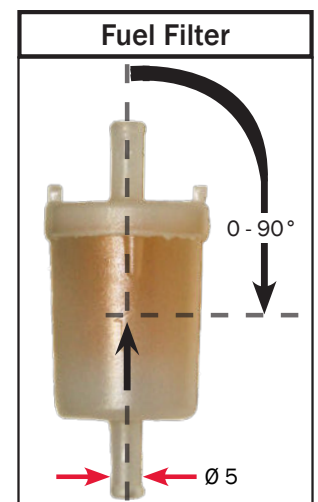
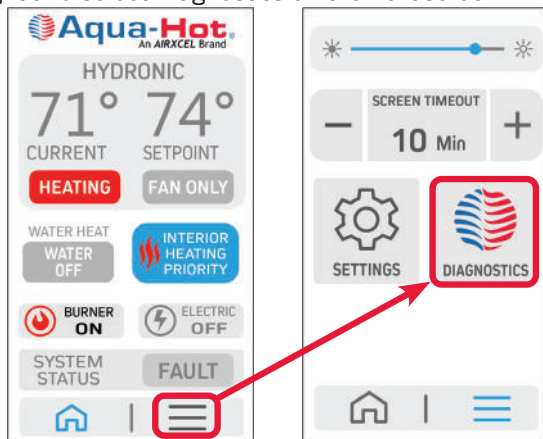

Figure 29

Inputting Serial Number

The LCD Screen set up is needed so the pump prime will be available for use.

1. Tap the screen to wake. Select the 3 lines on the bottom right and select Diagnostics on the next screen.



2. Tap serial number section to open Settings page:

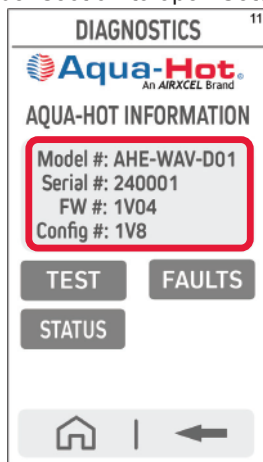

3. Select Serial Number and input your model and serial number information in and select Confirm: This information can be found on the Wave40 ID label, located on top of the Wave40.

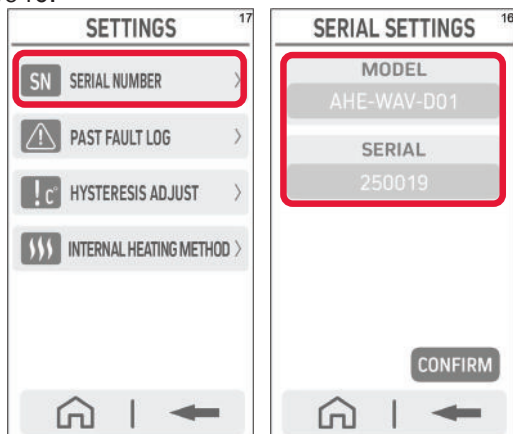

Fuel System Priming

For proper operation, the fuel system must be primed and free of air bubbles.

- Priming must be done prior to first operation or after the fuel filter has been replaced
- The fuel line must only be primed with the fuel line disconnected from the system.
- Place the disconnected end of the fuel line into a bucket or other receptacle to catch any fuel.
- With the fuel line disconnected from the system, navigate to the Oil Pump feature in the settings menu.
- **Hold down Oil Pump** to run until no air bubbles are seen in the clear fuel line.
- Reconnect the fuel line and check valve to the heater.

Instructions:

1. The diagnostics page can be accessed from the home screen by selecting the 3 lines on the bottom right, the selecting Diagnostics.

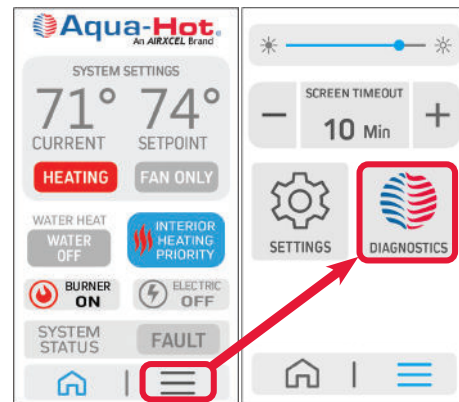

2. From the Aqua-Hot Information page, you can access the Test function. **Hold down the Oil Pump** to run until no air bubbles are seen in the clear fuel line.

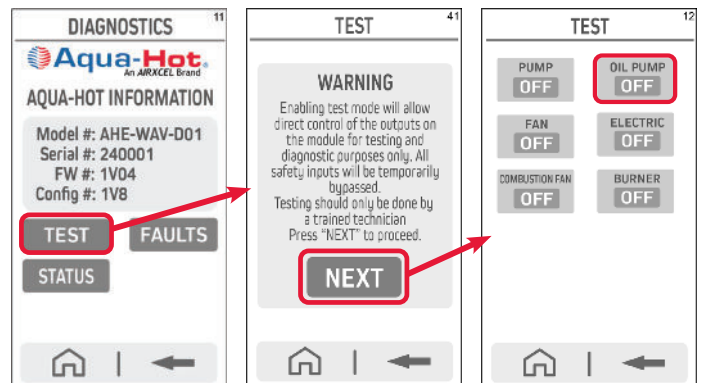

Domestic Water System

- All water pipes, valves, and connectors must be safe for drinking water, pressure resistant (up to 100 PSI/7Bar), and hot water resistant (up to 176 °F/80 °C).

NOTE: The water supply to the heater should not exceed 100 PSI.

- If the water pump is to be submerged, it is required to install a non-return valve between the pump and first water faucet on the cold water line.
- A pressure relief valve (125PSI/8.6Bar) must be installed to protect the system from overpressure.
- A tempering valve must be installed to protect against scalding water temperatures.
- The non-return valve (#6 Figure 30) must be installed in the proper direction:

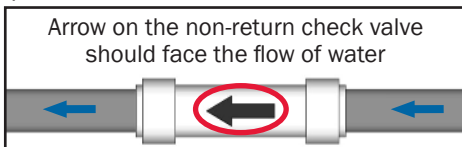

- All connections must be secured by clamps or crimp rings.

- A low point drain valve should be plumbed to the exterior of the vehicle on the cold water line of the system. The low point drain should be placed between the heater and the non-return valve on the cold water side.
- The pressure relief valve should be on the hot water line exiting the heater and be routed to drain outside of the vehicle.

The domestic water system must be installed by a qualified technician and must follow all local code requirements or regulations.

Reference the diagram below for more information.



DANGER

Water temperature over 125°F (82°C) can cause severe burns instantly, or death from scalds. Water temperature coming from the heater will be at 160°F (91°C). Feel water before bathing or showering! Temperature limiting valves are available. A tempering valve must be used.

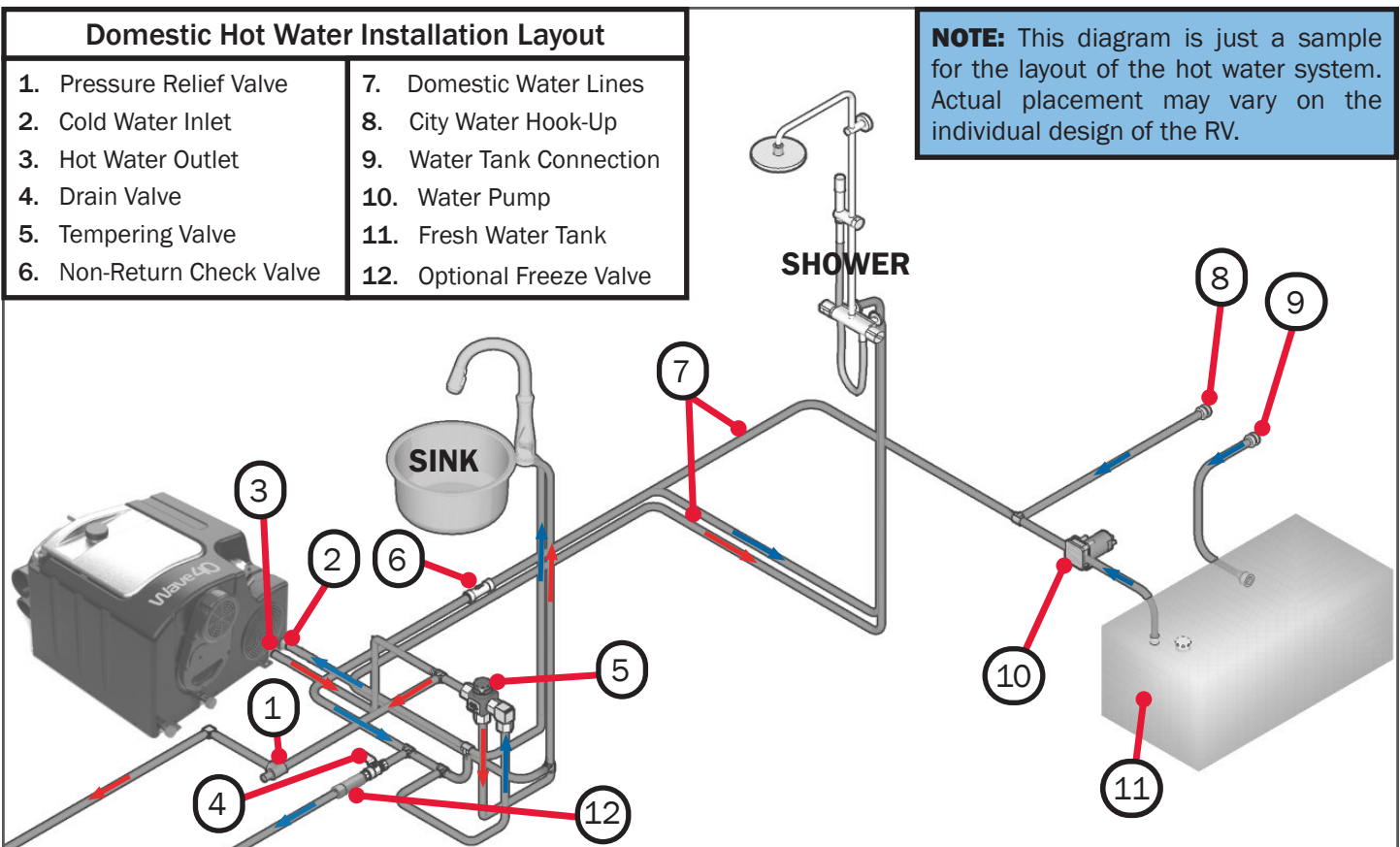

Figure 30

Filling the Water System

Before filling up the system with domestic water, confirm that the relief valve and drain valve are closed.

- Turn on the pump power supply at the pump switch.
- Open a hot water faucet in the RV and keep open until all air is purged from the line and water continuously flows.

⚠ DANGER



Risk of Severe Burn or Death from Scalds. Water temperature over 51°C (123.8°F) can cause severe burns instantly or death from scalds. See instruction manual before setting temperature at water heater. Feel water before bathing or showering. Temperature limiting valves are available, see manual.

WARNING:
HOT WATER CAN PRODUCE 3RD DEGREE BURNS
- IN 6s at 60°C (140°F)
- IN 30s AT 54°C (129.2°F)
WATER DELIVERY TEMPERATURE MIXING VALVE WAS FACTORY SET AT 49°C (120.2°F).
CONTACT QUALIFIED SERVICE PERSONNEL FOR ADJUSTMENTS.

Risque de brûlures graves ou la mort de brûlures. De l'eau à une température au-dessus de 51 °C (123,8 °F) peut ébouillanter et causer instantanément des brûlures graves allant jusqu' à la mort. Consultez le manuel d'instructions avant de régler la température du chauffe-eau. Vérifiez la température de l'eau avant de prendre un bain ou une douche. Des soupapes de limite de température sont disponibles, voir le manuel.

AVERTISSEMENT:
L'EAU CHAUDE PEUT PRODUIRE DES BRÛLURES DE TROISIÈME DEGRÉ
- EN 6s à 60°C (140°F)
- EN 30s à 54°C (129.2°F)
LA VANNE DE MÉLANGE DE TEMPÉRATURE D'ALIMENTATION EN EAU A ÉTÉ RÉGLÉE EN USINE À 49 °C (120,2 °F).
CONTACTER DU PERSONNEL DE SERVICE QUALIFIÉ POUR LES ADJUSTEMENTS.

LDE-003-260

Disinfecting the Domestic Water System

NOTICE

The Aqua-Hot Heating components are not compatible to prolonged exposure to sodium hypochlorite (bleach or liquid bleach). Using products containing bleach, including water refreshers, may cause corrosion of the domestic water lines, resulting in a catastrophic failure of the Aqua-Hot system by creating leaks that cannot be repaired. This damage is not covered by the Aqua-Hot warranty.

If disinfecting the hot water system, be sure to follow any current national regulations or any other applicable local standards for Water Systems.

NOTE: Extended exposure to household bleach will corrode the components of the Aqua-Hot will potentially dramatically shorten the operational lifetime of the Aqua-Hot. Under no circumstances is the Aqua-Hot to be exposed to household bleach for extended periods of time.

Connecting the Thermistor

The thermistor must be installed or the system will not operate properly. It is recommended to install the sensor away from direct heat.

Installation

1. For best performance, the sensor should be mounted unobstructed to the ambient cabin air.
2. Drill mounting hole Ø 0.5in (12mm)
3. Route wires to the Wave40 unit "P4".

Electrical Connections

The electrical panel is located on the heater under the cover as shown below. The cover can be removed by pulling from the top to release. Make sure the connecting cable is not pulled out when removing the cover.

Install wires away from sharp edges and metal surfaces, exhaust pipes, and fuel lines.

Connector cables and plugs should not be forced. Use tie-cables and fasten them to the housing with straps. The cables should not be able to loosen or disconnect when vehicle and heater are in operation.

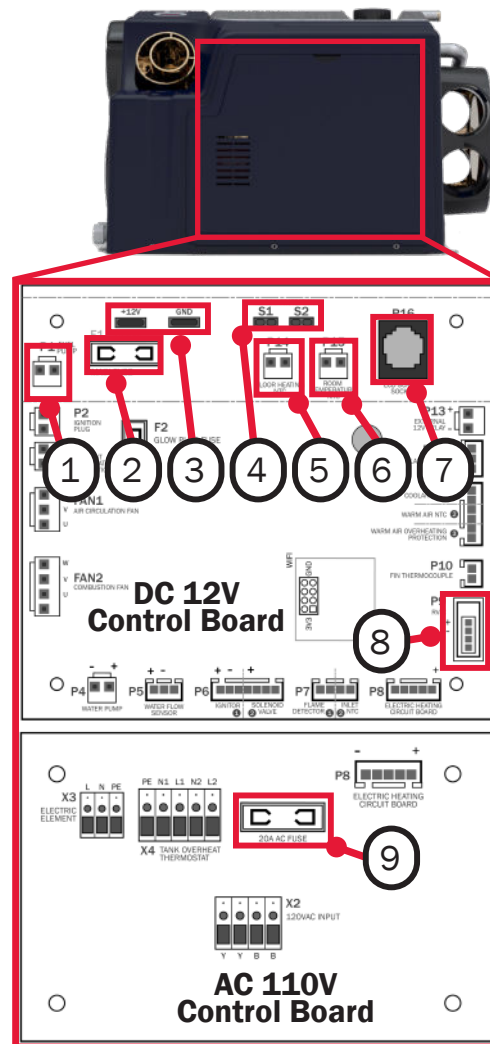

Figure 31

Controller Connections	
1. P1: Fuel Pump	6. P4: Room Thermostat NTC
2. F1: 20A Fuse	7. P23: Touchscreen Cable
3. Battery 12V / Ground	8. P9: Communication
4. S1-S2: Window Switch	9. F2: 20A Fuse
5. P3: Hydronic Thermostat NTC	

Connecting to 12V DC Power

Follow all guidelines and pay attention to all notes contained herein. Failure to adhere to these guidelines can inhibit unit performance, and may cause damage to the Aqua-Hot and/or the RV.

- Installation must be performed by a qualified professional according to current national regulations.
- The 12-volt supply to the heater must be connected to the battery and protected by an in-line fuse (20A).
- The main power and ground wires for the system should be installed directly to the vehicle battery as shown in the diagram below. The lines must be protected.
- The power supply cable must have a gauge of:
 - 14 AWG up to 10ft (3m) in length
 - 12 AWG up to 16ft (5m) in length
 - 10 AWG up to 25ft (7.6m) in length

For lengths greater than 20ft (6m), please contact Aqua-Hot.



CAUTION

DO NOT connect 12V DC power to the Aqua-Hot if the vehicle requires welding. Electrical welding will cause serious, irreversible damage to the Aqua-Hot.



WARNING

ELECTRICAL SHOCK HAZARD

The heater must be connected to a ground.

Connecting the Aqua-Hot to AC Power

The following section will detail how to connect the Aqua-Hot to the vehicle's AC electric system. When the RV is connected to an AC power source (plugged into shore power or a generator), the Aqua-Hot tank is heated by a 900W/1800W electric element. When ELECTRIC is turned on, DC power at the controller permits flow to the AC relay, which then activates the relay to send AC power to the electric element. The element will then heat the tank to between 165-180°F (74-82°C).

- Installation must be performed by a qualified professional according to current national regulations.
- The heater must be connected to a 110V AC supply and be protected with a 20A breaker. The 110V AC must be separate from 12V DC.
- The Aqua-Hot uses a NEMA 5-20 plug.
- It must be possible to disconnect the power to the heater, either an easily accessible plug or a circuit breaker.
- The 110V AC circuit must be GFCI protected.

Installing Display Backup Battery

- Open the controller panel and install a **CR1220** battery. Reference the Schematic on page 29.

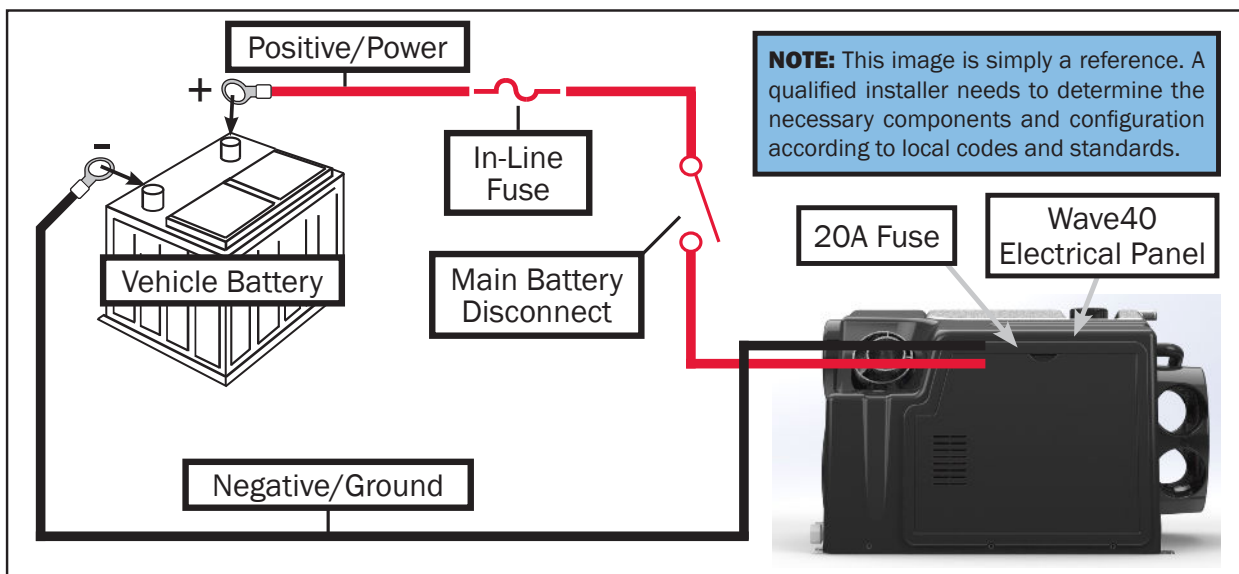
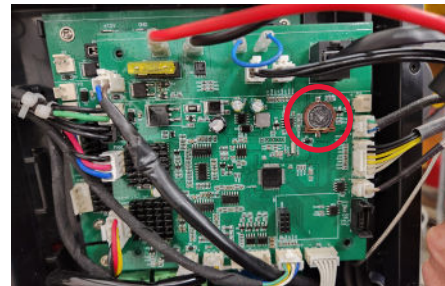

Figure 32

Aqua-Hot LCD

Mounting Considerations:

NOTE: The main 12VDC must be removed before disconnecting or reconnecting the communication cable.

- Route the 19.5ft (6m) Communication cable from the intended mounting position of the LCD to the Aqua-Hot Controller.
- The LCD screen is powered via the Communication cable which connects directly to the Aqua-Hot Controller.
- The screen requires at least ¾" (1.9cm) of backside clearance to allow room for cables and connections.

Mounting Procedure

1. Select a location within the RV.
2. Cut a 1½" (75mm) round hole in the RV wall for the wiring.
3. Using four countersunk #6 screws, secure the LCD bracket into place over the cutout just made.
4. Connect the Communication cable to the back of the LCD screen. Reference Figure 33.
5. Snap the LCD screen into the mounting bracket.



Figure 34

NOTE: Please note that the LCD Screen mounting bracket may only be mounted in this configuration as shown below. The screen will not fit in properly any other way.

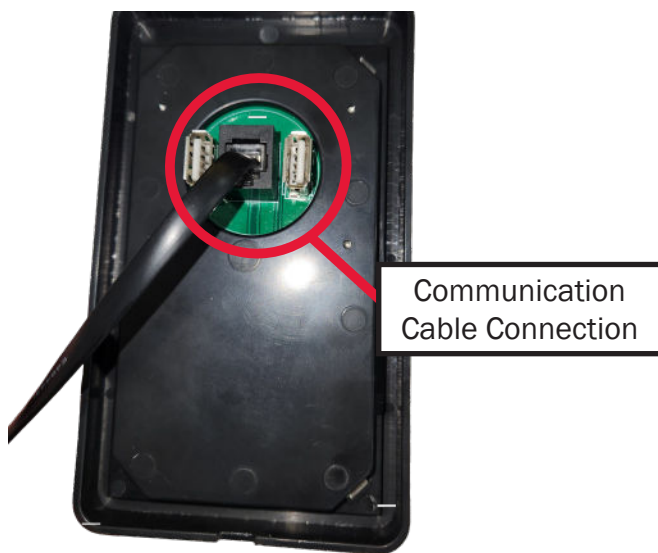

Figure 33

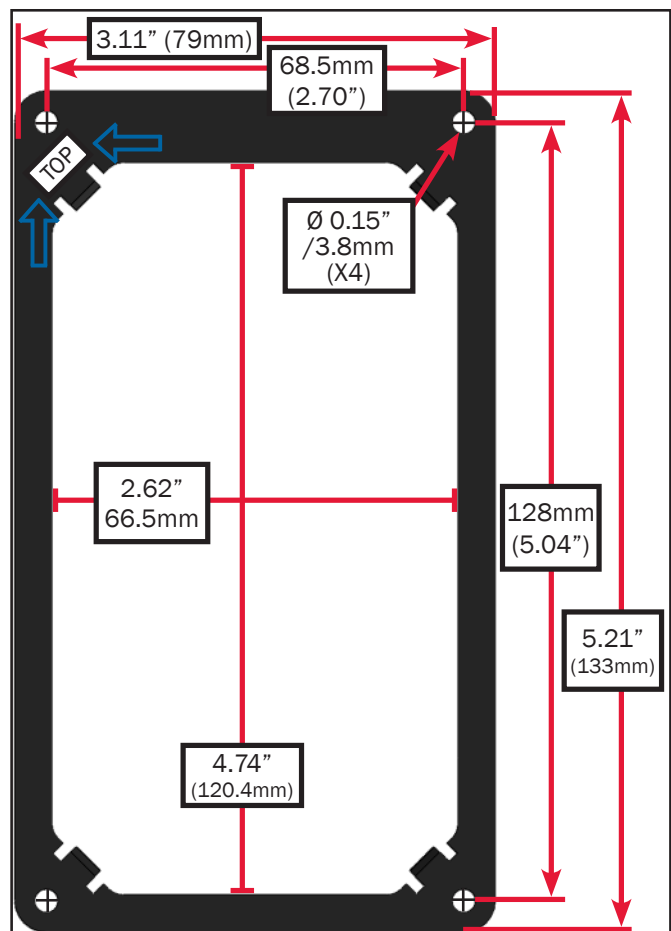

Figure 35

Inputting Serial Number

Introduction:

This section will outline the basic user-facing functionality of the Aqua-Hot LCD. Interior temperature set points, temperature units (°C/F), and Aqua-Hot diagnostics can all be accessed from the first two landing screens.

Home Page (no Hydronic Heat):

From the home screen, the end-user will select their interior temperature set-points and water heat levels, activate or deactivate the diesel burner and/or the electric element.

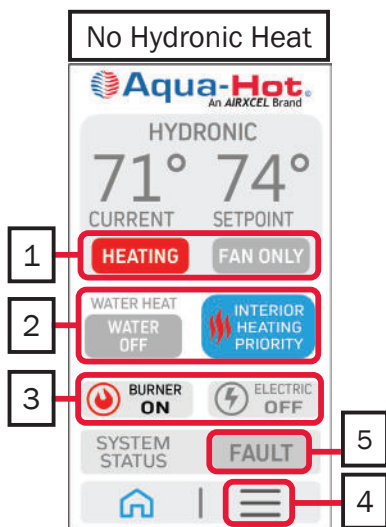

Basic Settings

Status (1):

HEATING This section shows the heating status only. "Heating" is red when system is heating air and/or water, and attempting to reach the target set point. "Fan Only" is red when the blower has been manually turned on, but is not heating the air. Both "heating" and "fan only" will be gray when off.

FAN ONLY

HEATING

FAN ONLY

Water Heating & Interior Heating Priority (2):

WATER HEAT LOW This section shows the status of Water Heating and Interior Heating Priority. Water Heating will be red when on, and show LOW or HIGH. It will be gray when off and show OFF.

WATER HEAT HIGH

WATER HEAT OFF Tap and hold to turn OFF hot water.

INTERIOR HEATING PRIORITY Interior Heating Priority is to give priority to interior heat over water heating. It will be blue when ON, or gray when OFF.

Burner & Electric Status (3):

BURNER ON This section shows the status of the Burner and Electric heating. When the Burner is on, the flame symbol is red with ON.

ELECTRIC HIGH Tap and hold to turn OFF Electric

ELECTRIC LOW The Electric when on, will show the electric symbol red with either LOW or HIGH. When off, the Electric symbol is gray, and OFF.

ELECTRIC OFF

Settings and Diagnostics Page (4):

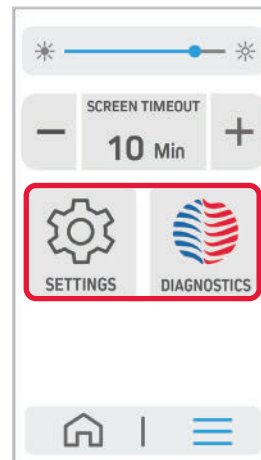

"Settings" is further described on page 29.

"Diagnostics" is further described throughout this manual.

Selecting the **Home** button will return back to the Home screen.

Fault Page (5):

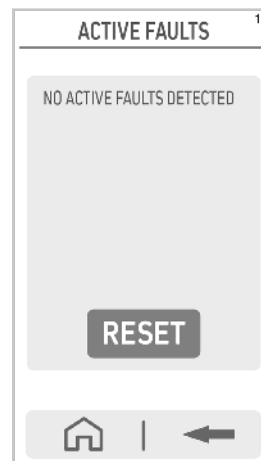

Selecting on **FAULT** will bring up the Fault page, showing any current Faults. You can select the "Reset" button to clear any faults.

INTERIOR HEAT & HYDRONIC

Settings & Functions:

Setting **INTERIOR HEAT** and **HYDRONIC HEAT** Tap on three lines, tap on diagnostics, tap on serial number page. Then select **INTERNAL HEATING METHOD** select **INTERIOR HEAT** **HYDRONIC** option.

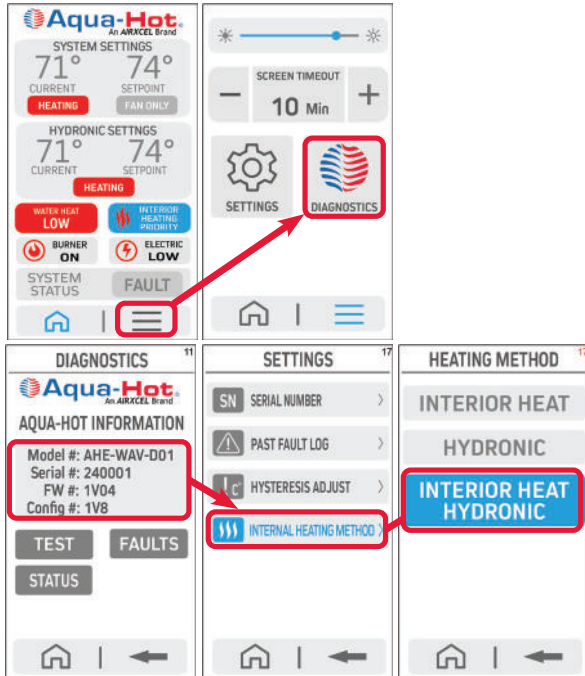

Home Page (Hydronic Heat)

From the home screen, the end user will select their interior temperature set-points, activate or deactivate the diesel burner and/or electrical element.

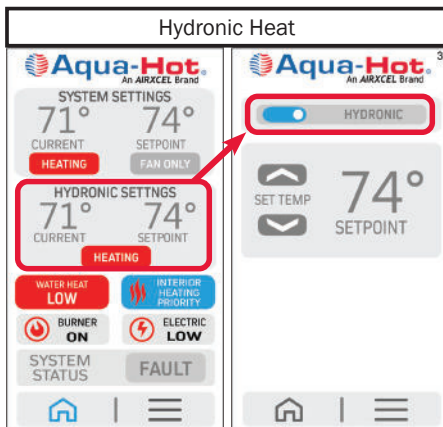

To turn on, tap on **HYDRONIC SETTINGS**. Switch on **HYDRONIC** and adjust to preferred temperature setting using the arrows. Tap the Home icon to return. Turn **BURNER** or **ELECTRIC** or both for heating.

Hydronic Screen Function

The screens will automatically update to show the setting(s) selected. The heating option can be Hydronic, or Interior heat only, or both hydronic and interior heat combined.

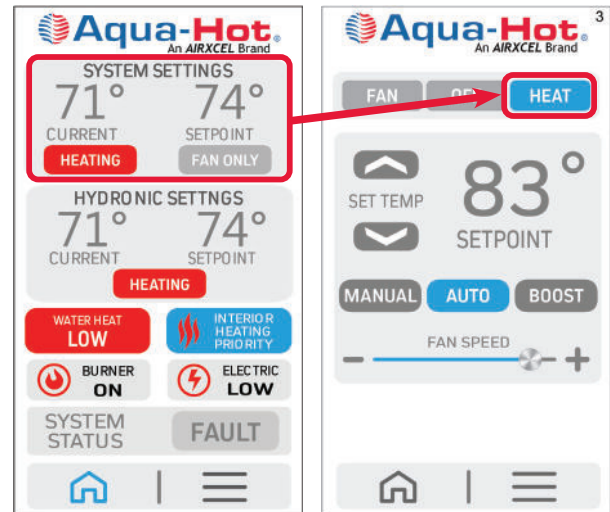

- **Manual:** When the Blower Fan Setting Parameter is set to **MANUAL**, select a value between 10% and 100% (in 5% increments). In this mode, the blower fan operates at a constant speed anytime the system determines that interior heat is called for.
- **AUTO:** When the Blower Fan Setting Parameter is set to **AUTO**, the system automatically modulates the blower fan speed based on the difference between the set-point temperature and the current temperature (as determined by the Zone Thermistor).
- **BOOST:** When the Blower Fan Setting Parameter is set to **BOOST**, the blower fan operates at maximum speed until the Zone Thermistor reading next indicates that interior heat is no longer required. Boost may *only* be selected by the user if Interior Heat is active. Once the system completes a heating cycle, Boost is automatically disabled and the system reverts to the blower fan speed dictated by the active Blower Fan Setting Parameter (either manual or auto).

INTERIOR HEAT

Settings & Functions:

To set **INTERIOR HEAT**, tap on the three lines, then on Diagnostics. On the Diagnostics page, tap on the serial number section then select **INTERNAL HEATING METHOD**, then select **INTERIOR HEAT**.

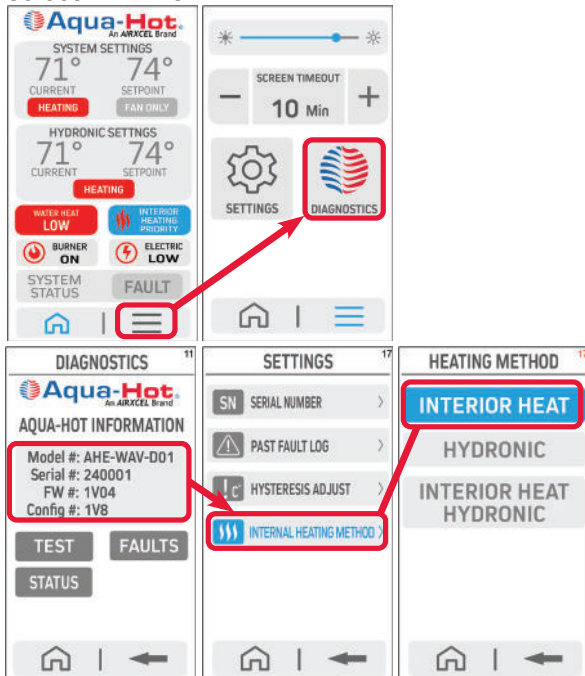

Home Page (Interior Heat):

From the home screen, the end user will select their interior temperature set-points, activate or deactivate the diesel burner and/or electrical element.

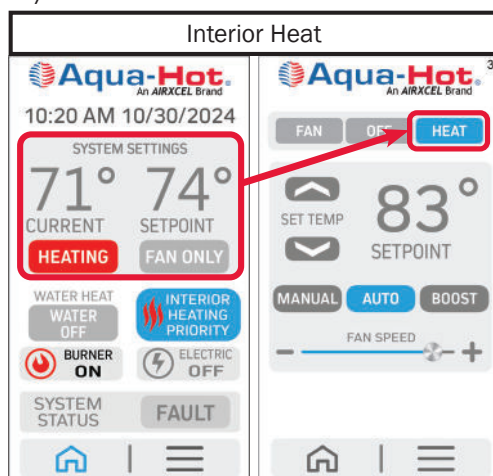

To turn on, tap on **SYSTEM SETTINGS**. Switch on **HEAT** and adjust to preferred temperature setting using the arrows. Tap the Home icon to return. Turn **BURNER** or **ELECTRIC** or both for heating.

FAN MODE ONLY

In **FAN MODE**, burner will **not** turn on.

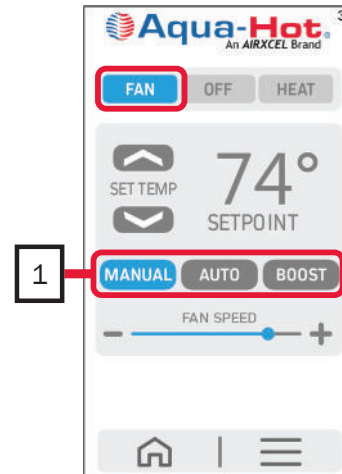

Fan Speed Settings

- Manual:** When the Blower Fan Setting Parameter is set to **MANUAL**, select a value between 10% and 100% (in 5% increments). In this mode, the blower fan operates at a constant speed anytime the system determines that interior heat is called for.
- AUTO:** When the Blower Fan Setting Parameter is set to **AUTO**, the system automatically modulates the blower fan speed based on the difference between the set-point temperature and the current temperature (as determined by the Zone Thermistor).
- BOOST:** When the Blower Fan Setting Parameter is set to **BOOST**, the blower fan operates at maximum speed until the Zone Thermistor reading next indicates that interior heat is no longer required. Boost may only be selected by the user if Interior Heat is active. Once the system completes a heating cycle, boost is automatically disabled and the system reverts to the blower fan speed dictated by the active Blower Fan Setting Parameter (either manual or auto).

HYDRONIC

Settings & Functions:

Setting **INTERIOR HEAT**: Tap on the three lines, tap on Diagnostics, tap on serial number section. Then select **INTERNAL HEATING METHOD** select **HYDRONIC** option.

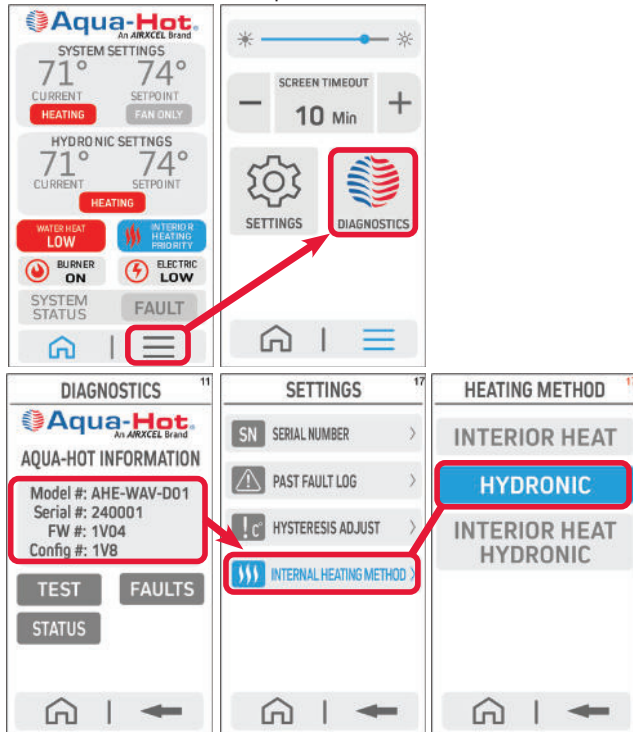

The Hysteresis setting will apply to both interior heat and to hydronic.

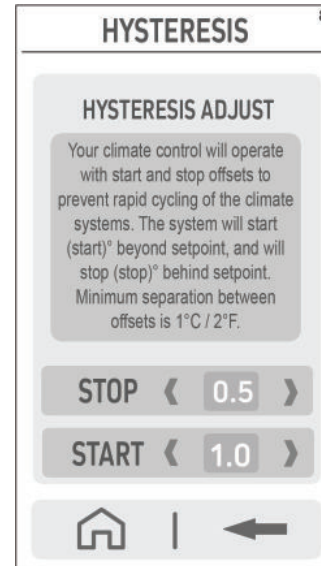

Home Page (Hydronic)

From the home screen, the end user will select their interior temperature set-points, activate or deactivate the diesel burner and/or electrical element.

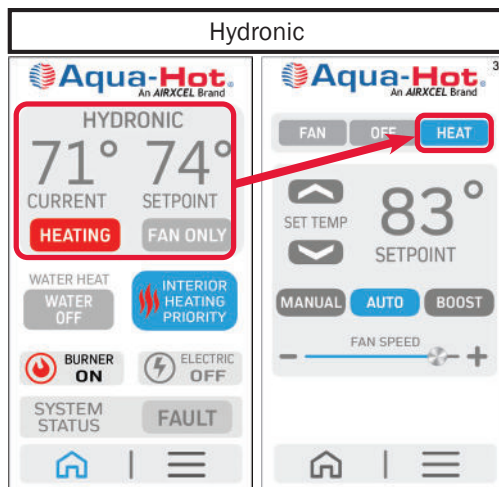

To turn on, tap on **HYDRONIC SETTINGS**. Switch on **HYDRONIC** and adjust to preferred temperature setting using the arrows. Tap the Home icon to return. Turn **BURNER** or **ELECTRIC** or both for heating.

When **HEAT** is selected, the **FAN** cannot be turned on.

Temperature Unit Settings:

The Temperature Unit Settings page can be accessed from the Home screen by selecting the 3 lines on the bottom right, then selecting Settings. Tap on Temperature Unit settings to set Celsius or Fahrenheit.

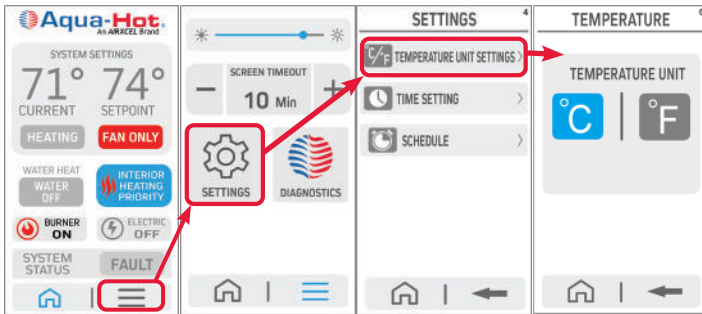

Time Settings:

The Time Settings page can be accessed from the Home screen by selecting the 3 lines on the bottom right, then selecting Settings. Tap on Time setting to set 12 or 24 hour system, set the date and time.

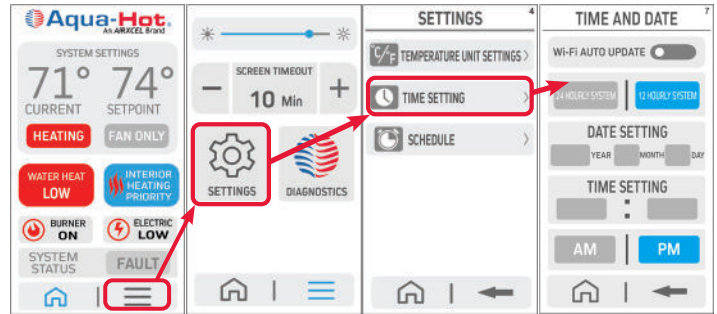

Additional Settings

Settings:

The Settings page can be accessed from the home screen by selecting the 3 lines on the bottom right, then selecting Settings. From this page, you can set the temperature units, time, and schedule. Reference the next page for detailed information on settings.

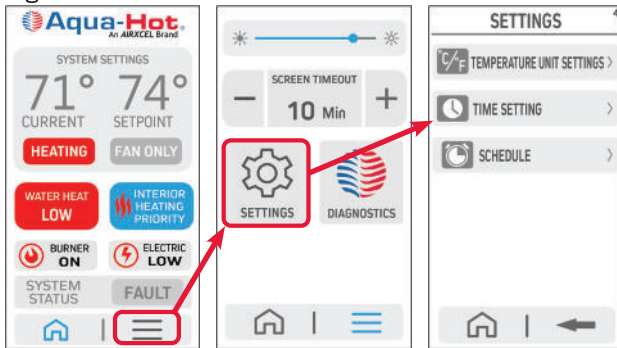

Schedule Settings:

The Schedule settings page can be accessed from the Home screen by selecting the 3 lines on the bottom right, then selecting Settings. Tap on Schedule to set the heating schedule and modes. Do NOT schedule if the vehicle will be in storage.

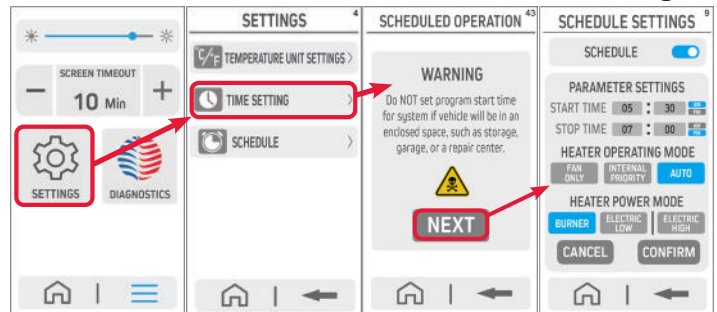

Test Page:

From the Aqua-Hot Information page, you can access the Test function. This will allow for testing of certain Aqua-Hot components. Testing should only be done by a trained technician.



Hysteresis Setting ON/OFF:

The Hysteresis setting prevents constant on-off switching of the heating system. This setting defines a range between a minimum and maximum temperature. When the temperature drops to the minimum value, the heating system turns on. When the temperature reaches the maximum value, the heat is turned off. This setting may be adjusted due to uneven heating of the vehicle or adjusted to calibrate the remote room thermostat location to overall vehicle temperature and allow the heater to run longer to circulate the air flow. This setting reduces wear on equipment and increases interior comfort.

For example, a thermostat with a hysteresis of 2°F(1°C) and a set temperature of 70°F (21°C) will turn the heating on at 68°F (20°C) and off at 72°F (22°C).

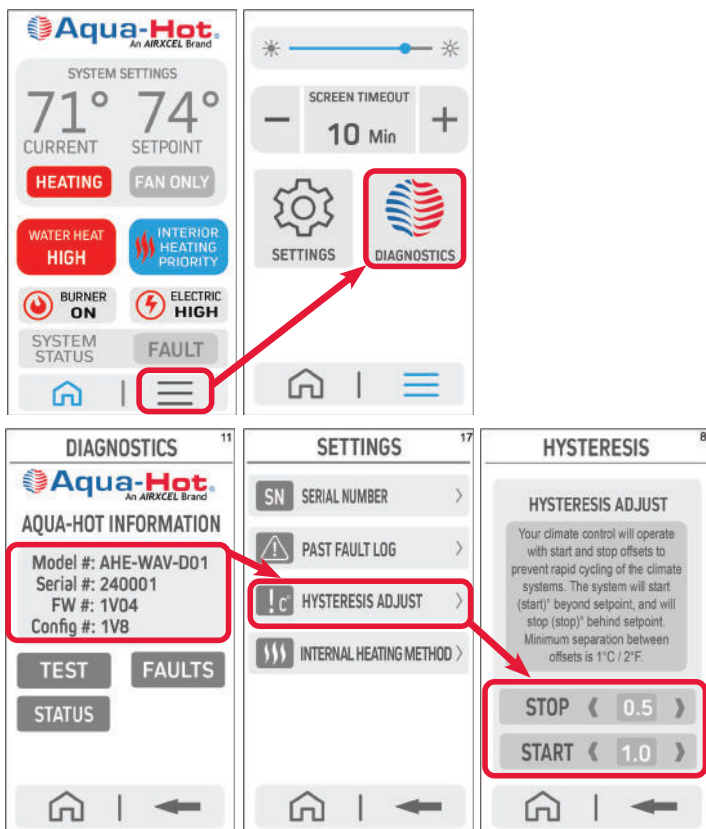

Information Pages

Status Page:

From the Aqua-Hot Information page, you can access the Status screen. This will show detailed information about the system. Any errors or issues will show in red.

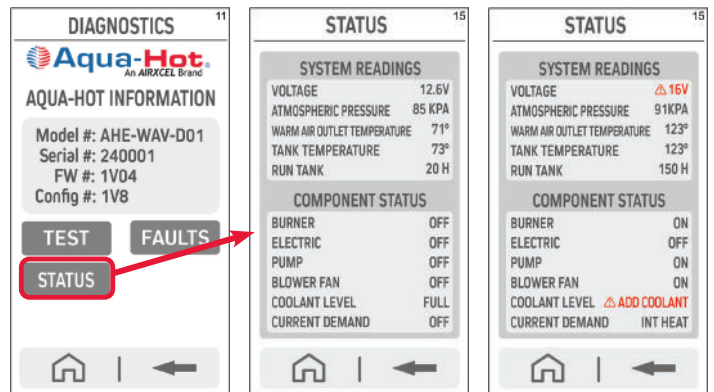

Faults Page:

From the Aqua-Hot Information page, you can access the Faults screen. This will show any faults within the system. This page can also be accessed from the Home screen by tapping on Faults.

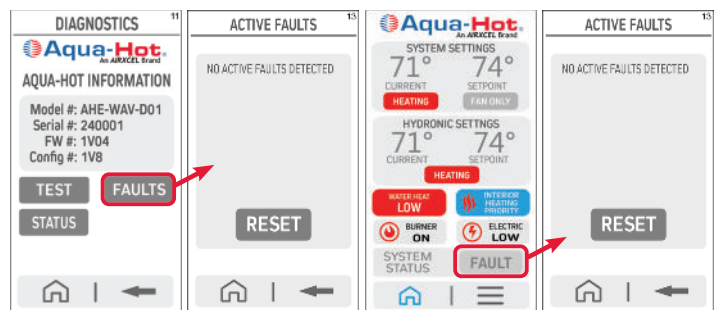

Filling the Aqua-Hot

Recommended is a tank drain valve for systems without hydronic loop at the unit's auxiliary (AUX) port outlet.

Aqua-Hot offers a assembly for this connection, part number PLX-WAV-400 illustrated in the parts and accessories section.

Before the first activation of the Aqua-Hot, fill the unit with antifreeze and water heating solution. Without the solution present, the Aqua-Hot will not operate. Follow the directions below to fill the Aqua-Hot with antifreeze and water heating solution.

In order to provide the best freeze protection, boil-over protection, anti-corrosion, and rust protection, a mixture of 50/50 **Ethylene Glycol** antifreeze and distilled water is recommended. The Aqua-Hot Wave40 boiler tank holds approximately 3.25 gallons (12.3L).

The mixture may be modified to provide the most adequate freezing, boiling, and rust/anti-corrosive protection. A 50/50 mixture of **Ethylene Glycol** antifreeze and distilled water has a freeze point of approximately -29°F (-34°C), and a boiling point of approximately 223°F (106°C).

Instructions:

1. Open the Tank Bleed Valve.
2. Add 3 gallons (11.4L) at the top recovery tank filler cap.
3. Monitor the bleed valve for fluid to exit while adding an additional ½ gallon (1.9L) of ethylene glycol. Close the valve once fluid is present.

NOTE: Applications using the Hydronic Heating Loop will require additional steps/glycol to bleed the system. Ensure the hose is 6" (15.24cm) above the expansion bottle.

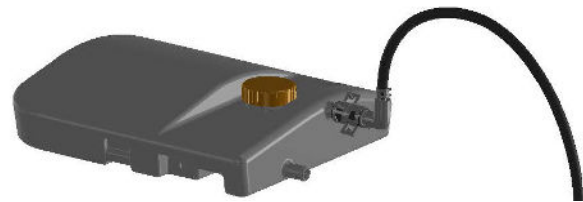

Figure 37

Initializing the Aqua-Hot

Activation Instructions:

1. Make sure power supply to the Aqua-Hot is on. Use the LCD to operate.
2. Confirm that the water tank is adequately filled. Make sure to flush the domestic water system thoroughly with clean water prior to use.
3. Confirm the water system has been properly purged of any air.
4. Confirm there is adequate diesel fuel and the fuel system has been purged.
5. Operate the heater approximately 20 minutes for the system to heat the interior.
6. Switch the heater to water heat. Allow approximately 20 minutes for tank to heat. Turn on hot water faucet to verify plumbing is operating as it should.

Once these checks have been confirmed, the heater is now ready for normal operation and use.

The Wave40 can be filled from the drain port.

- If using Hydronic loop, shut the ball valve on the aux supply to ensure the zone loop fills first.
- If not using Hydronic loop, you can still fill the Aqua-Hot from the drain port using PLX-WAV-400.

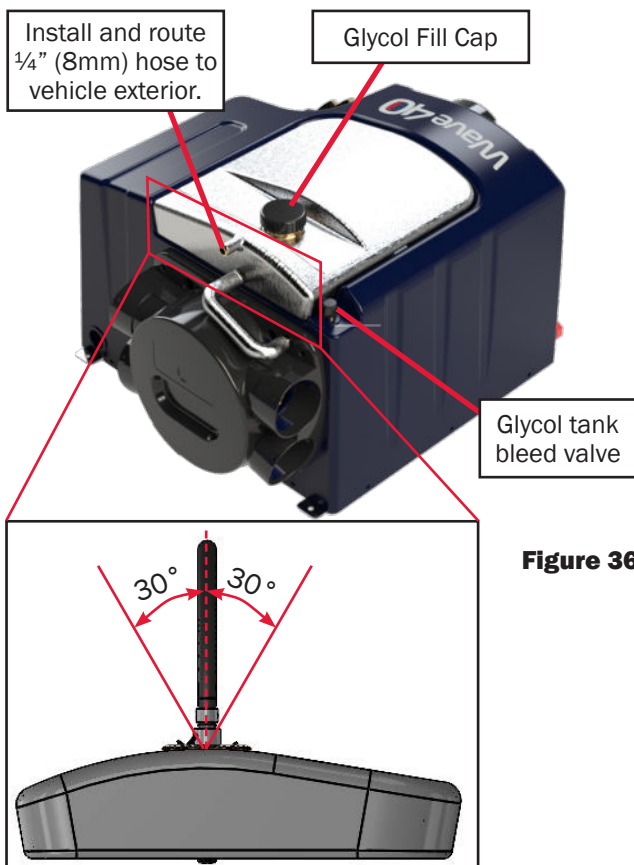

Figure 36

Communication Network Connectivity (optional)

NOTE: For networked control of the LCD, Aqua-Hot requires system integrators ensure that individual commands are received and processed. Aqua-Hot requires that commands be repeated or confirmed so that if a single message were dropped, or if there is a brief network disturbance, the LCD would get into the correct state as soon as the disruption was removed.

It is imperative that installers and Communication integrators follow all directions outlined in the Aqua Hot Communication Integration Manual to ensure safe operation of the system.

Communication Network Port - Bridge Module		
Pin Number	Description	Color
1	12V DC Power	Red
2	CAN H	White
3	CAN L	Green
4	Ground	Black

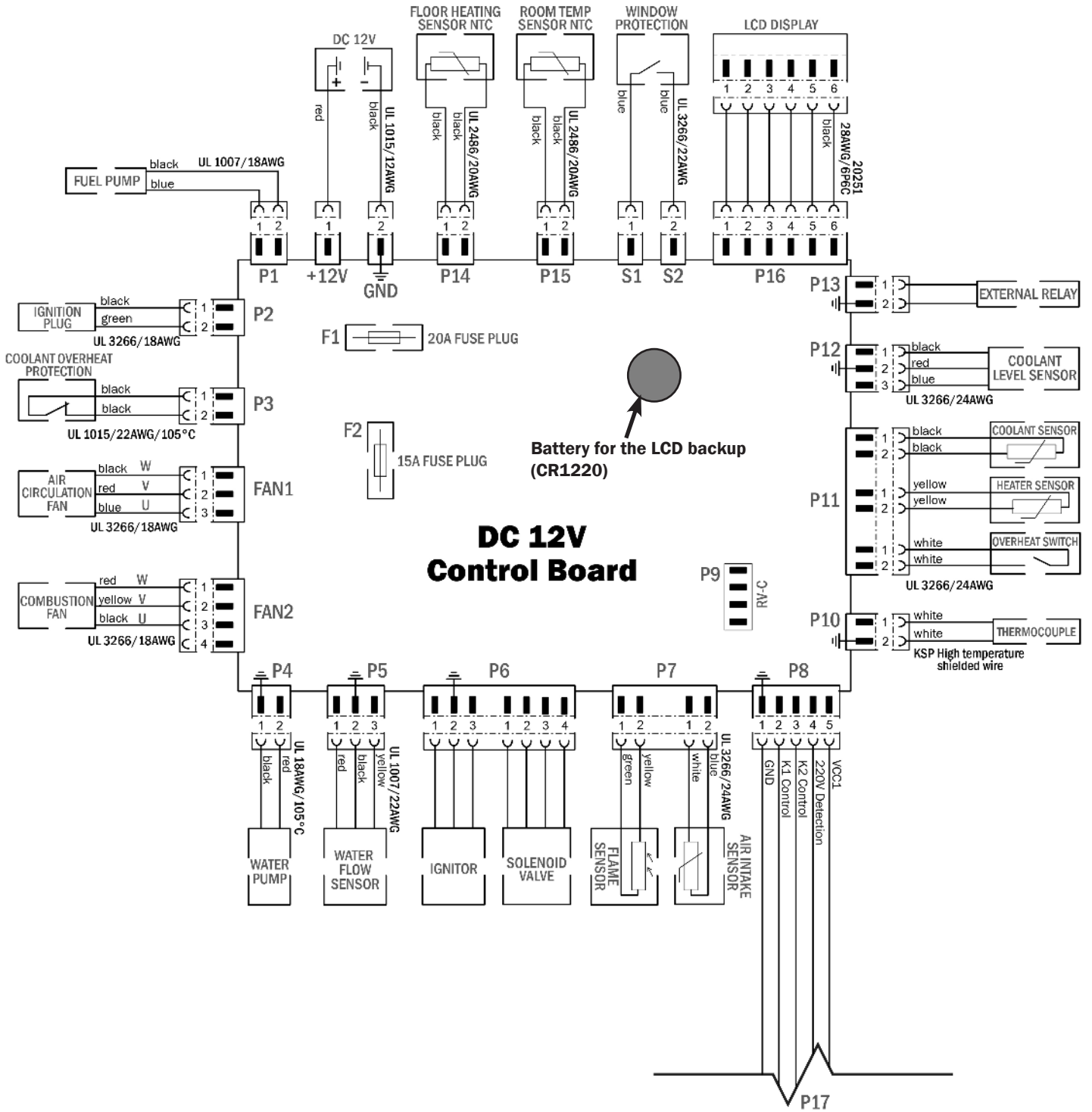
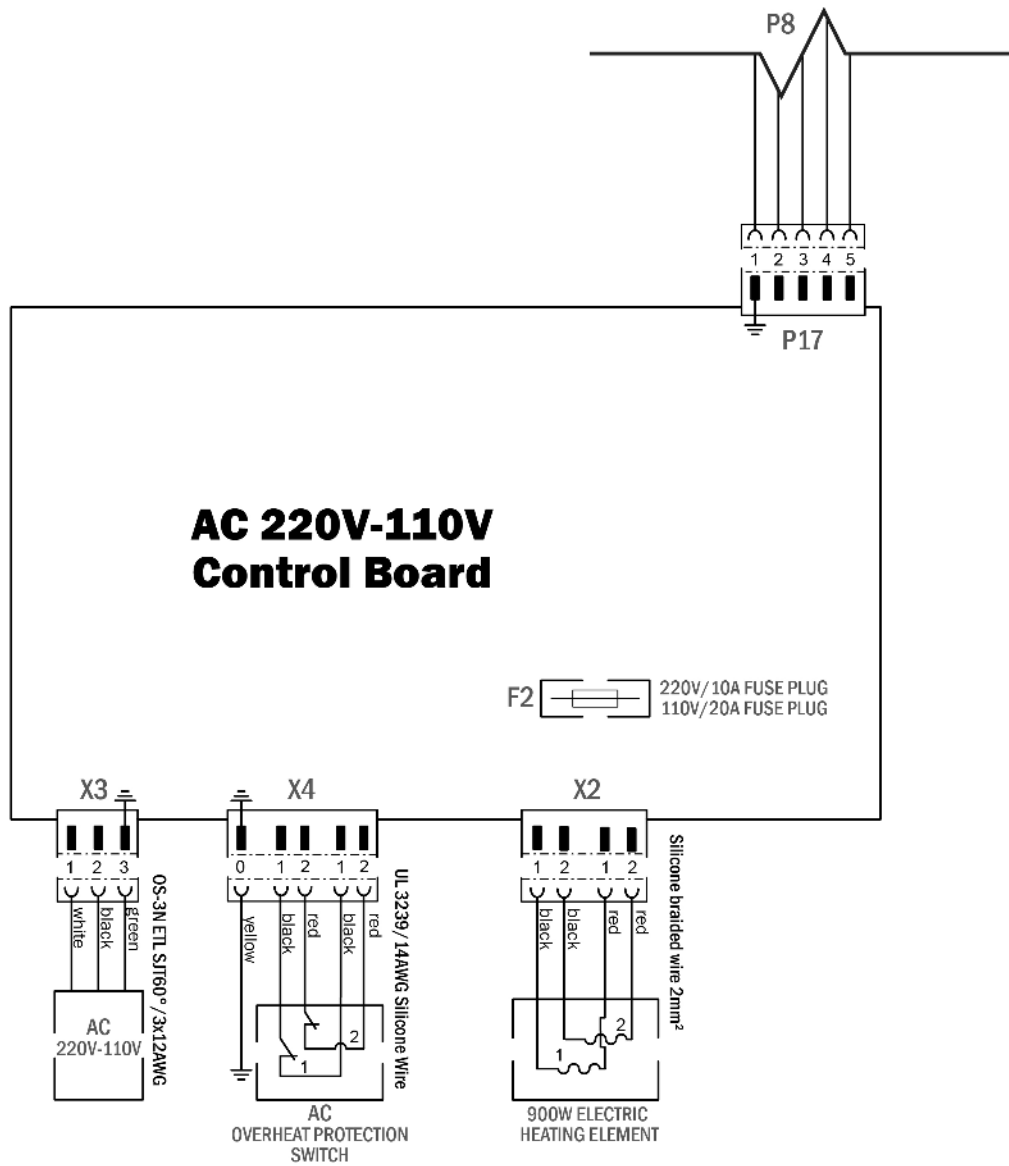

Figure 38

Operational Specs	
Operational Voltage Range	10V to 16V
Source Voltage Must Not Exceed	16 VDC
Operational Current Draw	0.1A





Winterization

To avoid freeze damage to the system, the heater must be drained completely. If water is left in the system in below freezing temperatures, it can cause severe damage to the system that is not covered under warranty.

NOTE: The Aqua-Hot can continue to be used for interior heat once the domestic hot water system has been winterized.



WARNING

Not winterizing the Aqua-Hot when freezing temperatures are present will result in serious damage to the Aqua-Hot domestic water heating system. The warranty does not cover freeze damage.

Maintenance & Storage

To maintain the Aqua-Hot at its full potential, it is highly recommended to have the burner tuned up annually.

NOTE: If white or black smoke is seen, this is a good indicator that service is necessary.

- Replace the fuel filter
- Check the air ducting, air intake and exhaust outlet for blockages or damage
- Check for damage or breaks in the fuel lines and wiring.

If the system has not been used for long periods of time, thoroughly flush all hot/cold water lines before use. It is recommended to run the heater at least once a month for 10-20 minutes to ensure optimum heater condition.

System Checks

Please do the following checks prior to the first operation to confirm the installation was done properly and safely.

1. Test all water connections and fuel connections/lines for any leaks. Make sure all the hose clamps are properly positioned and secured.
2. Ensure there is protection on any sharp edges or objects for the water and fuel lines, and wiring.
3. Make sure there the operating voltage is greater than 11.5V.
4. Make sure the power and ground connections are properly secured and installed.
5. Check that the fuses are in their proper, specified locations.
6. Make sure the fuse boxes are secure and protected from any water sources.
7. Ensure the vehicle battery is mounted properly and all connections are secure, and has a full charge.
8. The exhaust pipe should be a safe distance from any flammable materials (at least 2 inches).
9. Exhaust opening should be a safe distance away from any vehicle interior openings and should be directed to not cause back pressure while driving.
10. The air intake should get fresh air away from the direction of travel.
11. Ensure the air intake system is properly secured.

Once the system checks are complete and it has been confirmed that all is properly and safely installed, please continue to the first operation.



WARNING

AQUA-HOT HEATING UNIT

Avoid the Risk of Explosion:

- Switch Heater off at filling stations and areas where explosive materials, fumes, and dust may collect.

Avoid the Risk of Asphyxiation:

- Never operate heater in closed spaces such as garages and shops without adequate ventilation or exhaust extraction.

For further information on the safe operation of your Aqua-Hot heater, refer to your Aqua-Hot operating manual.

LDE-101.125

Troubleshooting

- Ensure that the system is supplied with electrical power and there are no blown fuses.
- Ensure that there is at least ¼ tank of fuel in the vehicle fuel supply and the fuel filter is not clogged.
- Make sure all the electrical and plumbing connections are connected and secure.
- Ensure there are no faults on the LCD. If there are, determine the fault and remedy. Refer to the table below for the fault code.

Fault Codes				
Error Code	Fault Name	Remedy	Component Values (approx. @ 75°F/24°C)	
E10	DC Voltage too high	Check vehicle power supply	> 16vDC	
E11	DC Voltage too low	Check vehicle power supply	< 10.5vDC	
E21	Hot air temperature sensor open circuit	Check temperature sensor connections	1.69KΩ	
E22	Warm air outlet temperature sensor short circuit	Check temperature sensor wiring		
E23	Coolant temperature sensor open circuit	Check temperature sensor connections	1.397 kΩ	
E24	Coolant temperature sensor short circuit	Check temperature sensor wiring		
E25	Air heat thermistor open circuit	Check thermistor wiring	0.31 Ω	
E26	Air heat thermistor short-circuit	Check thermistor wiring		
E27	Combustion thermistor open circuit	Check temperature sensor connections	IAT Sensor	4.45 kΩ
E28	Combustion thermistor short-circuit	Check temperature sensor wiring	IAT Sensor	
E31	Start up ignition failure	<ul style="list-style-type: none"> • Check fuel supply system • Check intake and exhaust • Check ignition/glow plug • Check DC power supply • Check flame sensor 	<ul style="list-style-type: none"> • Flame sensor: Flame (12.4KΩ), No Flame (128.9KΩ) • Glow plug (0.68 Ω) 	
E32	Combustion interruption			
E34	Flame sensor open circuit	<ul style="list-style-type: none"> • Check flame sensor wiring • Check flame sensor 	Light (12.4KΩ) Dark (128.9KΩ)	
E35	Flame sensor short-circuit			
E37	Circulating pump disconnected	<ul style="list-style-type: none"> • Check pump wiring 	399KΩ	
E38	Circulating pump failed to start	<ul style="list-style-type: none"> • Check pump wiring 		
E41	Combustion air inlet overheat	<ul style="list-style-type: none"> • Check sensor wiring 	13.3KΩ	
E42	Combustion thermistor too high	<ul style="list-style-type: none"> • Check temperature sensor connections 		
E43	Coolant temperature overheat	<ul style="list-style-type: none"> • Check sensor wiring • Check coolant temperature 		

Error Code	Fault Name	Remedy	Component Values (approx. @ 75°F/24°C)
E46	Coolant level is too low	<ul style="list-style-type: none"> • Check sensor wiring • Check coolant level 	1.28M Ω
E48	Warm Air overheated	<ul style="list-style-type: none"> • Check sensor wiring • Check warm air temperature 	100k Ω
E51	Communication Failure Cable Disconnected	<ul style="list-style-type: none"> • Check network cable • Check heater power • Check PCB 	
E61	Fuel Pump Open Circuit	<ul style="list-style-type: none"> • Check fuel pump lead for damage • Check fuel pump wire connections • Check fuel pump • Check PCB 	5M Ω
E62	Fuel pump short circuit	<ul style="list-style-type: none"> • Check fuel pump lead for damage • Check fuel pump wire connections • Check fuel pump • Check PCB 	
E63	Glow plug failure	<ul style="list-style-type: none"> • Check glow plug wiring 	Glow plug (0.68 Ω)
E81	Combustion air fan open circuit	<ul style="list-style-type: none"> • Check combustion fan wiring • Check combustion fan 	0.59 Ω
E82	Combustion air fan fails to start	<ul style="list-style-type: none"> • Check combustion fan wiring • Check combustion fan 	
E84	Air blower open circuit	<ul style="list-style-type: none"> • Check combustion air blower motor • Check combustion fan wiring 	0.62 Ω
E85	The warm air blower fails to start	<ul style="list-style-type: none"> • Check warm air blower motor • Check warm air blower wiring 	
E87	Hydronic Thermistor Open-Circuit	<ul style="list-style-type: none"> • Check thermistor wiring 	12KΩ
E88	Warm air blower speed too low	<ul style="list-style-type: none"> • Check thermistor wiring 	
Alarm			
110	Window protection	<ul style="list-style-type: none"> • Close window • Check window alarm bridge/wiring 	
120	DC Voltage Too Low	<ul style="list-style-type: none"> • Check power supply and connections 	< 10.5vDC
220	AC Open-Circuit	<ul style="list-style-type: none"> • Check AC connections • Check fuse 	
No Fault Code			
		<ul style="list-style-type: none"> • Water Flow Switch 	.50MΩ
		<ul style="list-style-type: none"> • Flame Detector Open Circuit 	

Heater Lock-out Reset Procedure

To reset the heater from a lock-out, simply turn off the heater and disconnect power supply to the heater, wait for 20 seconds, then reconnect power supply and restart the system.



AQUA-HOT™ (2) YEAR LIMITED WARRANTY

Aqua-Hot Heating Systems Inc. warrants the AQUA-HOT heater to the original owner to be free from defects in material and workmanship under normal conditions of designed usage and service as outlined in the installation and operator manuals for a period of two (2) years covering both parts and labor beginning on the date of purchase of the vehicle by the original owner. Replacement parts are covered for the remainder of the heating systems warranty. All purchased replacement parts will carry a six months, (180) days warranty.

This warranty does not apply to scheduled maintenances items such as fuel filters and fuel nozzles, damage or failure of the AQUA-HOT heater or the vehicle into which it was installed due to improper installation, assembly, maintenance, abuse, neglect, accident, or the use of parts not supplied by Aqua-Hot Heating Systems, Inc. Aqua-Hot Heating Systems is not responsible for incidental or consequential damages.

The intent of this warranty is to protect the end user of the heating system from such defects, which might have occurred in the manufacture of the product. The warranty is not intended to protect the end user from problems, which are outside the ability of Aqua-Hot Heating Systems control.

To obtain a warranty repair authorization or information, please contact the Tech Support Department at 1-800-685-4298 (7:00am to 4:00pm Mountain Standard Time).

My Comfort Zones are On-Board

Vehicle:

Purchased From:

Dealer Information:

Name:

Location:

Phone Number:

Heating System:

Serial Number:



Scan the QR code on the right with your mobile device to take you to the website to register your Aqua-Hot product.

Installation Manual

Wave40 

 **Aqua-Hot**®
An AIRXCEL Brand

Wave40 DIESEL
AHE-WAV-D01



Aqua-Hot Heating Systems, LLC
7755 Miller Drive, Frederick, CO 80504

Visit us online at www.aquahot.com
Call us at (800) 685-4298 or (303) 651-5500

©2025 Aqua-Hot Heating Systems, LLC. Printed in the USA